

**Valvola di blocco semplice effetto con pilotaggio separato**  
**Single pilot operated check valve with vented pilot piston**  
**mod. VBS - L - PS**

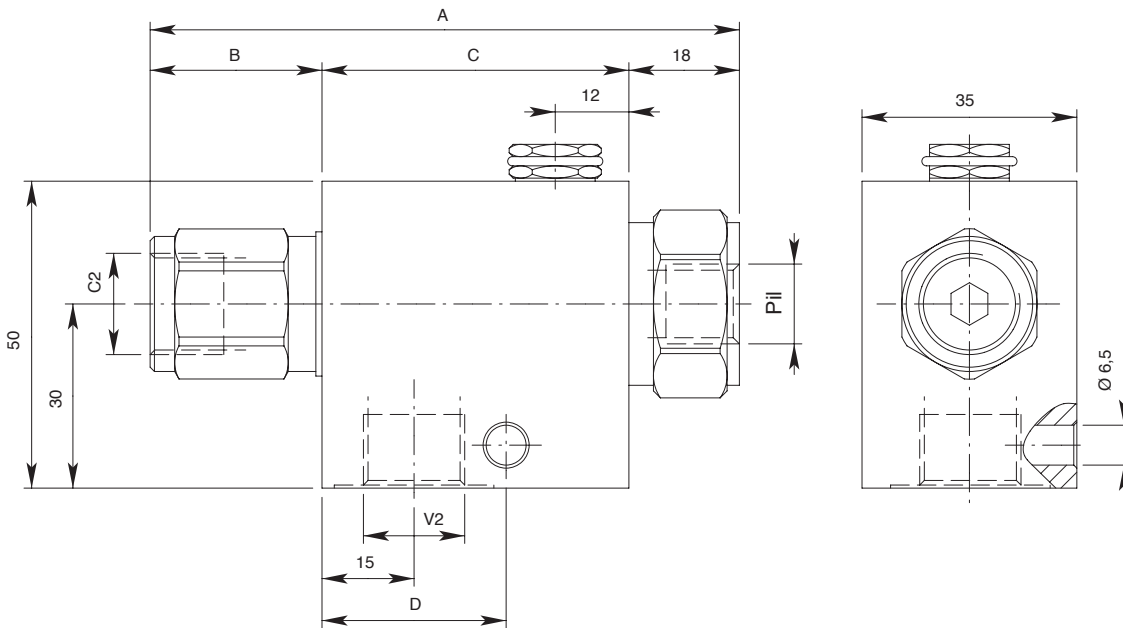
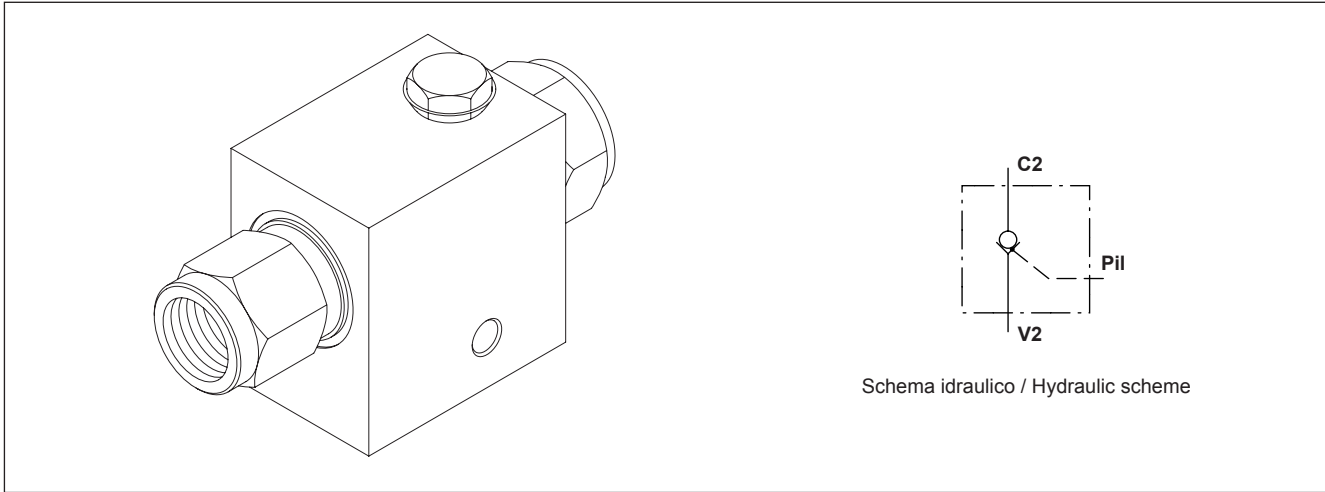

Modello Type	V2 - C2	P11	A	B	C	D	Portata max Max flow l / min	Rapporto pilotaggio Pilot ratio	Pressione massima Max pressure bar
VBS-L-PS-14	1/4" gas	1/4" gas	96	28	50	30	20	11/1	350
VBS-L-PS-38	3/8" gas	1/4" gas	96	28	50	30	35		
VBS-L-PS-12	1/2" gas	1/4" gas	105	35	52	32	50	6,25/1	

Tutti i dati forniti sono stati ottenuti usando olio con viscosità di circa 30cSt a 50°C. Campo di temperatura ammesso: -20°C, +90°C. Filtrazione assoluta: 25µ.  
I dati non sono impegnativi, **CBF** si riserva di apportare modifiche senza preavviso.  
All performances and calibrations are carried out by using hydraulic oil with viscosity approx. 30cSt at 50°C. Temperature range: -20°C, +90°C. Filtration absolute: 25µ. The specifications are not binding, **CBF** reserves the right to introduce modifications without notice.

**Sigla di ordinazione / Ordering code**

**VBS-L-PS-38**

Modello / Type

Molle - Springs	
Inizio apertura Cracking pressure bar	Colore Colour
5	Nero / Black