

The D1VW is a 3-chamber, electrically controlled 4/3 or 4/2 way directional control valve. It is activated directly by solenoids with screwed-in wet pin armature. The coils can be exchanged for various input voltages, however, a change between alternating (AC) and direct current (DC) is not possible.

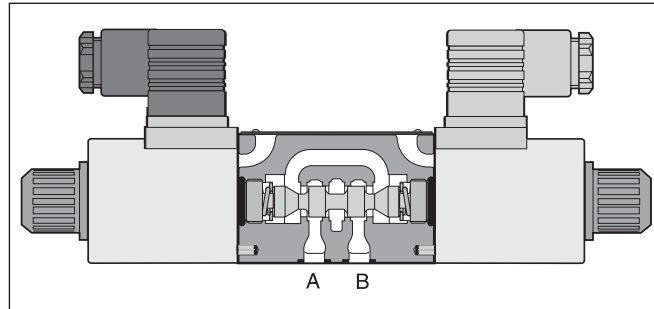
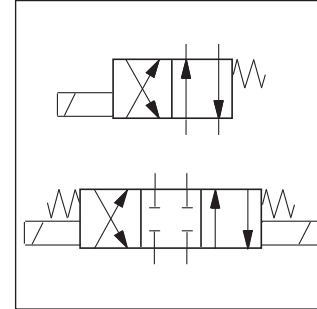
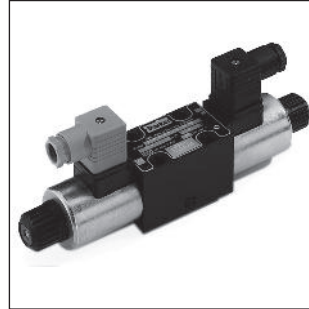

2

Technical data

General							
Design		Directional spool valve					
Actuation		Solenoid					
Size		DIN NG6 / CETOP 03 / NFPA D03					
Mounting interface		DIN 24340 A6 / ISO 4401 / CETOP RP 121-H / NFPA D03					
Mounting position		Unrestricted, preferably horizontal					
Ambient temperature	[°C]	-25...+50					
Weight	[kg]	1.5 (1 solenoid), 2.1 (2 solenoids)					
Hydraulic							
Max. operating pressure	[bar]	P, A B: 350 T: 210 (DC), 105 (AC), 210 (AC Code "H")					
Fluid		Hydraulic oil in accordance with DIN 51524 / 51525					
Fluid temperature	[°C]	-25 ... +70					
Viscosity permitted	[mm²/s]	2.8...400 (2.8...400 cSt)					
Viscosity recommended	[mm²/s]	30...80					
Filtration		ISO 4406 (1999); 18/16/13 (meet NAS 1638: 7)					
Flow max.	[l/min]	80					
Leakage at 50 bar	[ml/min]	Up to 10 per flow path, depending on spool					
Static / Dynamic							
Step response at 95%	[ms]	Energized: 32 (DC), 13 (AC) / De-energized: 40 (DC), 20 (AC)					
Electrical characteristics							
Duty ratio		100% ED; CAUTION: coil temperature up to 150 °C possible					
Max. switching frequency	[1/h]	15000					
Protection class		IP 65 in accordance with DIN 40050 (plugged and mounted)					
Supply voltage	Code [V]	K	J	U	G	Y	T
		12 VDC	24 VDC	98 VDC	205 VDC	110 at 50Hz / 120 at 60Hz	230 at 50Hz / 240 at 60Hz
Tolerance supply voltage	[%]	±10	±10	±10	±10	±5	±5
Current consumption	hold [A]	2.5	1.25	0.31	0.15	0.58 / 0.49	0.31 / 0.26
Current consumption	in rush [A]	2.5	1.25	0.31	0.15	2.1 / 2.0	1.05 / 1.0
Power consumption	hold [W]	30	30	30	30	64 / 59 [VA]	68 / 62 [VA]
Power consumption	in rush [W]	30	30	30	30	231 / 240 [VA]	231 / 240 [VA]
Solenoid connection		Connector as per EN 175301-803, solenoid identification as per ISO 9461. Conduit box with plug-in coil and central plug M12x1.					
Wiring min.	[mm²]	3 x 1.5 recommended					
Wiring length max.	[m]	50 recommended					

With electrical connections the protective conductor (PE ⚡) must be connected according to the relevant regulations.

D1VW STANDARD.PMD RH



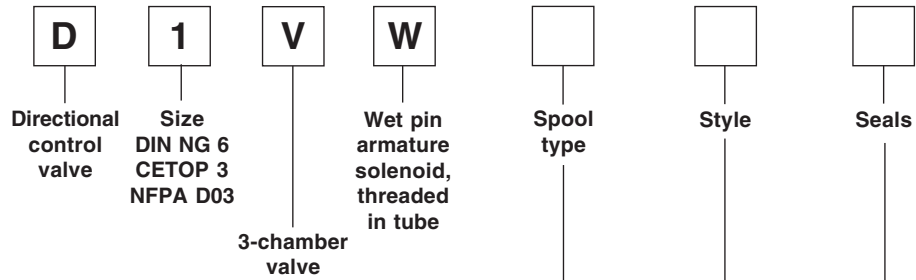

2

3 position spools	
Code	Spool type
1	
2	
3	
4	
5	
6	
7	
10	
11	
14	
15	
16	
21	
22	
31	
32	
76	
78	
81	
82	
102	

3 position spools	
Code	Spool type
8	
9	

2 position spools	
Code	Spool type
20	
26	
30	
101	

3 position spools (except spool 8 and 9)	
Code	Description
C	3 positions. Spring offset in position "0". Operated in position "a" or "b".
E	2 positions. Spring offset in position "0". Operated in position "a".
F	2 positions. Spring offset in position "b". Operated in position "0".
K	2 positions. Spring offset in position "0". Operated in position "b".
M	2 positions. Spring offset in position "a". Operated in position "0".

3 position spools (only for spool 8 and 9)	
Code	Description
C	3 positions. Spring offset in position "0". Operated in position "a" or "b".
E	2 positions. Spring offset in position "0". Operated in position "b".
F	2 positions. Spring offset in position "a". Operated in position "0".
K	2 positions. Spring offset in position "0". Operated in position "a".
M	2 positions. Spring offset in position "b". Operated in position "0".

2 position spools	
Code	Description
B	2 positions. Spring offset in position "b". Operated in position "a".
D	2 positions, detent. Operated in position "a" or "b". No centre or offset position.
H	2 positions. Spring offset in position "a". Operated in position "b".

Code	Seals
N	NBR
V	FPM

**Bold letters =
 Short-term availability**

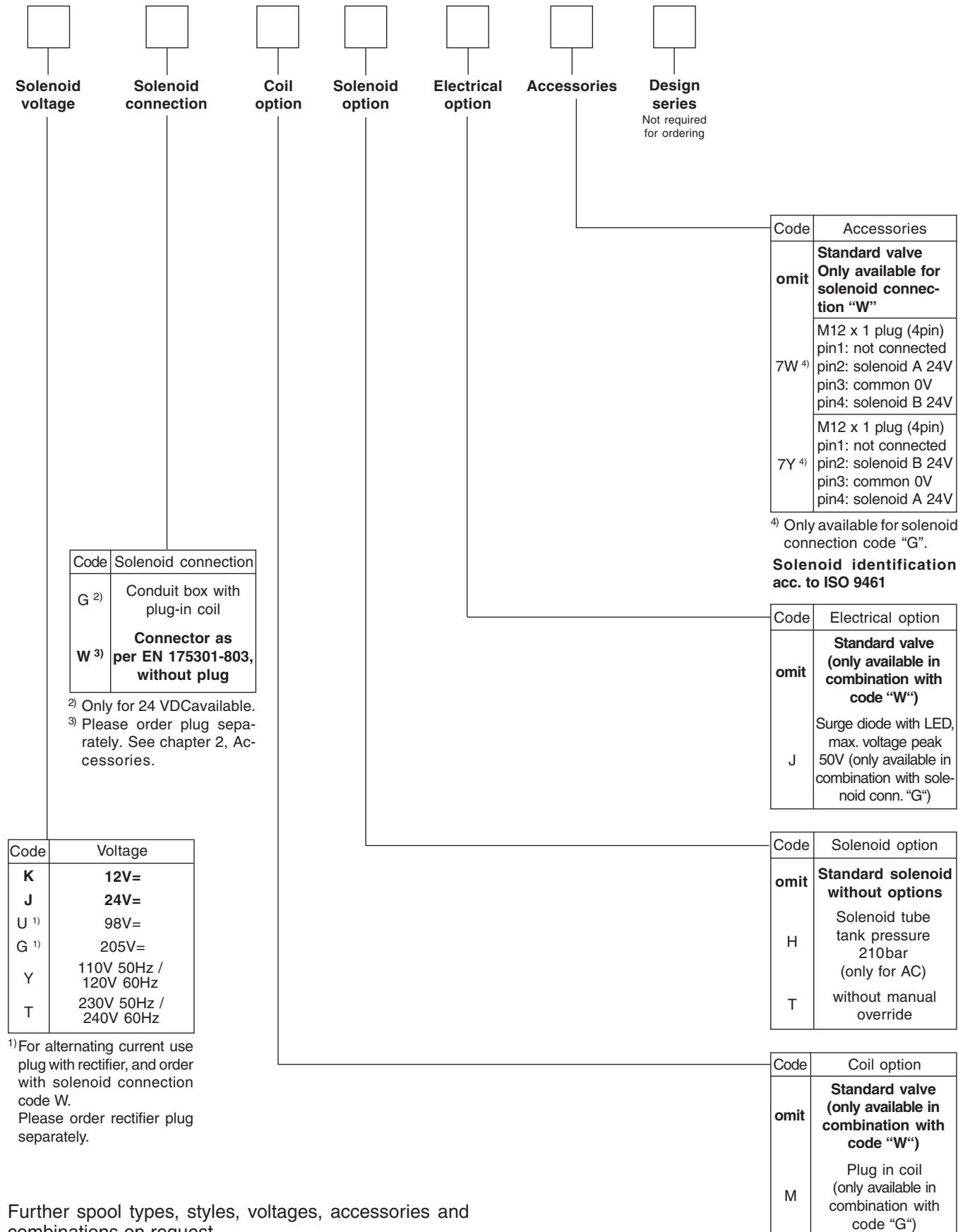

2

Further spool types, styles, voltages, accessories and combinations on request.

D1VW STANDARD.PMD RH



The flow curve diagram shows the flow versus pressure drop curves for all spools shown. To read the values in the diagram, the curve number for the selected spool and

desired operating position must first be determined from the table below.

2

Spool	Position "b"		Position "a"		Position "0"					
	P->A	B->T	P->B	A->T	P->A	P->B	A->T	B->T	P->T	A->B
1	4	1	4	1	-	-	-	-	-	-
2	5	2	5	2	4	4	1	1	6	1
3	4	1	4	2	-	-	8	-	-	-
4	4	2	4	2	-	-	7	7	-	9
5	4	1	5	1	9	-	-	-	-	-
6	5	1	5	1	9	9	-	-	-	9
7	5	2	4	1	-	5	-	1	7	-
10	4	-	4	-	-	-	-	-	-	-
11	4	2	4	2	-	-	11	11	-	-
14	4	1	5	2	5	-	1	-	7	-
15	4	2	4	1	-	-	-	8	-	-
16	5	1	4	1	-	9	-	-	-	-
20	5	1	5	1	-	-	-	-	-	-
26	6	-	6	-	-	-	-	-	-	-
30	5	1	5	1	-	-	-	-	-	-
76	-	2	-	-	-	-	3	-	-	-
78	-	-	-	2	-	-	-	3	-	-
81	10	10	10	10	-	-	-	-	-	-
82	10	10	10	10	-	-	1)	1)	-	-
	P->B	A->T	P->A	B->T	P->A	P->B	A->T	B->T	P->T	A->B
8	2	2	2	2	-	-	-	-	8	-
9	3	3	3	3	-	-	-	-	9	-
	Position "b"		Position "a"							
	P->A	P->B	A->B	P->B	A->T					
21	3	3	3	6	1					
	P->A	B->T		P->A	P->B	A->B				
22	6	1		3	3	3				

1) Only for pressure compensation, no high flow possible.

Flow curve

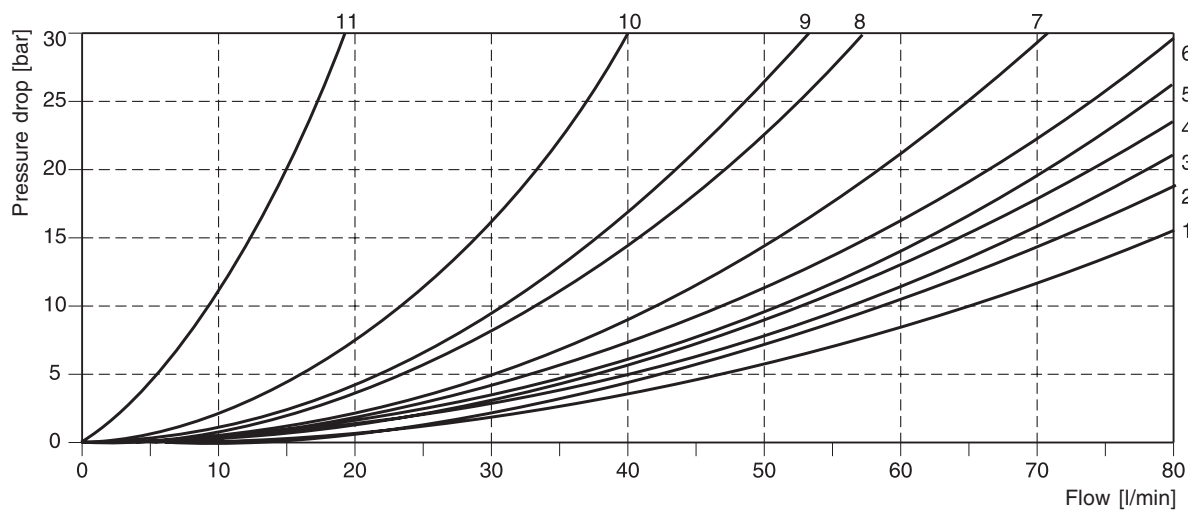

D1VW STANDARD.PMD RH



The diagram below specifies the shift limits for valves with DC solenoids. Valves of style "F" and "M" may only be loaded at 70% of the value. The specifications apply to a viscosity of 35 mm²/s and equal flow at A and B port.

These values can be considerably lower than the represented ones by unequal flow at A and B port. To avoid flow rates above the shift limits of the valve, a plug-in orifice can be inserted in the P port.

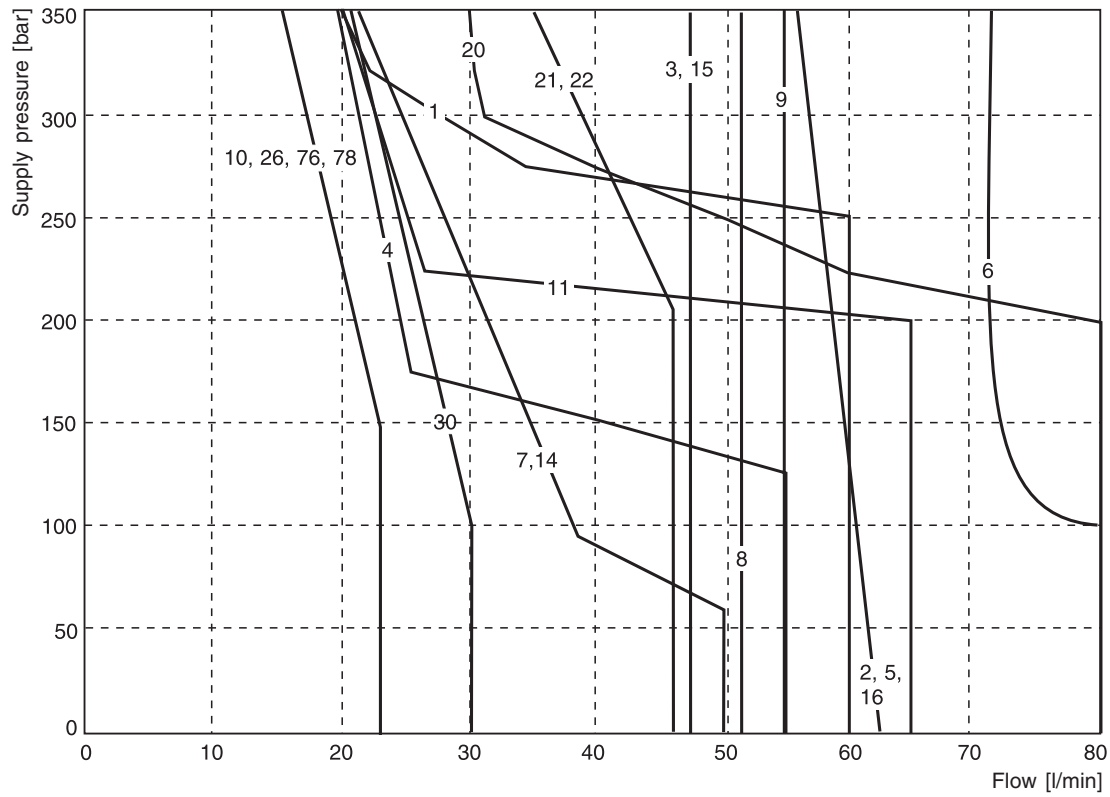

2

Pin assignment code "7W"

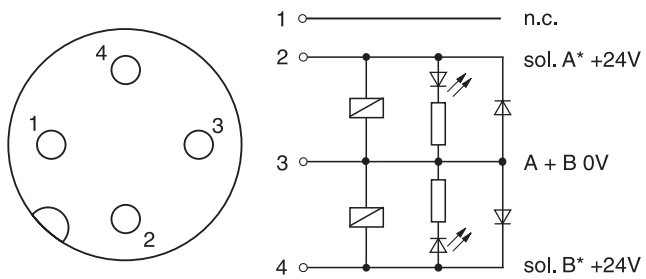

Pin assignment code "7Y"

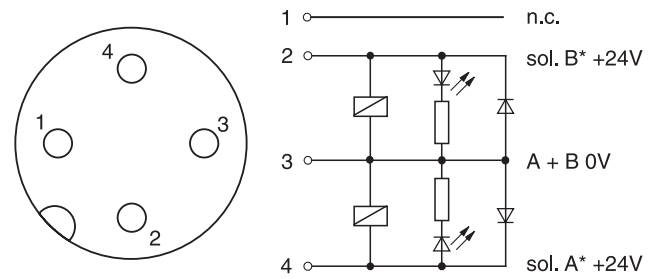

* Solenoid A: When energized, connects P to A.
 Solenoid B: When energized, connects P to B.
 (according to ISO 9461)

2

**Interface EN 175301-803, DC solenoid
 B, E, F -style**

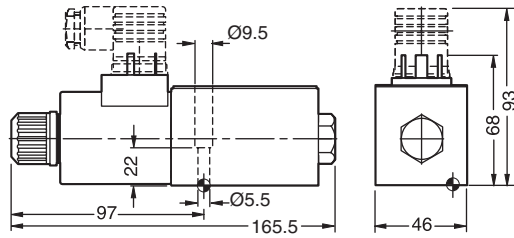

H, K, M -style

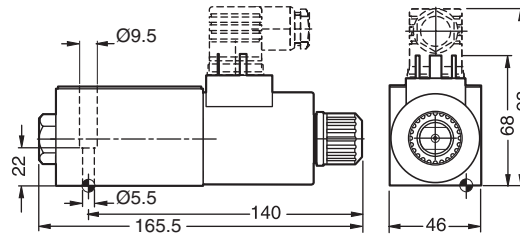

C, D -style

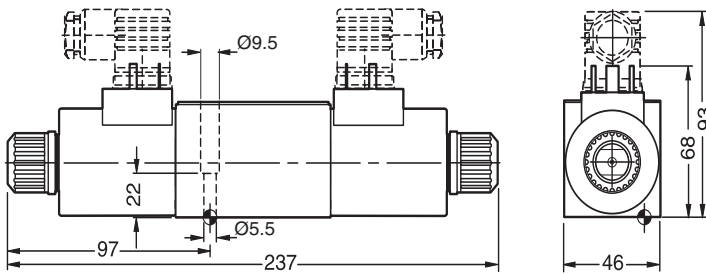

**Interface EN 175301-803, AC solenoid
 B, E, F -style**

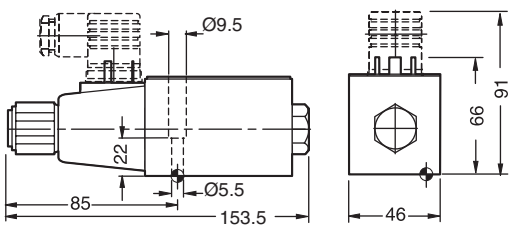

H, K, M -style

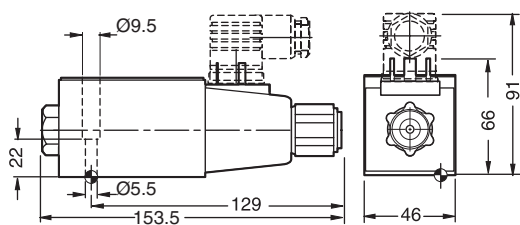

C, D -style

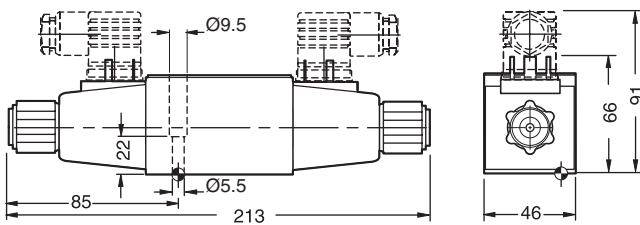

**Conduit box (only C, D -style shown)
 DC solenoid**

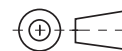
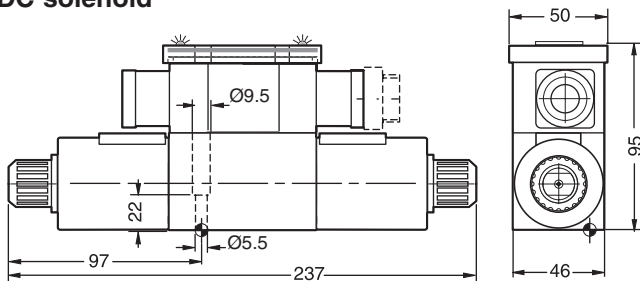

Surface finish	Kit	4x M5x30 DIN 912 12.9	6.8 Nm ± 15%	Kit
	BK375			NBR: SK-D1VW-70 FPM: SK-D1VW-V70

The space necessary to remove the plug per EN 175301-803, design type AF is at least 15 mm.
 The torque for the screw M3 of the plug has to be 0.5 to 0.6 Nm.

D1VW STANDARD.PMD RH

