



UNIVERSAL JOINT DRIVE TRAIN COMPONENTS SPLINED YOKES AND COMPANION FLANGES

SAFETY - Contact with spinning driveshaft can result in serious injury. Safety guards should be fitted to protect personnel from contact with rotating shafts, or to contain the shaft in the event of failure.

SPLINED CLAMPLOCK TYPE YOKES

Specially developed for positive connection of driveline to splined hydraulic pump shafts.
WIDE APPLICATION RANGE. CLAMPLOCK yokes are available to fit SAE or metric hydraulic pumps or motor spline types found on mobile equipment.
PREVENTS FRETTING OR FLOGGING. The double bolt split clamp design locks solid on to splines giving long trouble free life.
HIGH STRENGTH FOR LONG LIFE. CLAMPLOCK yokes are manufactured from steel to a high degree of precision, accuracy and strength.



CLAMPLOCK YOKES

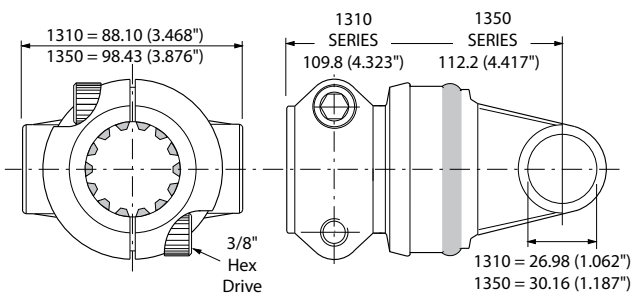

INTEGRAL CLAMPLOCK YOKES

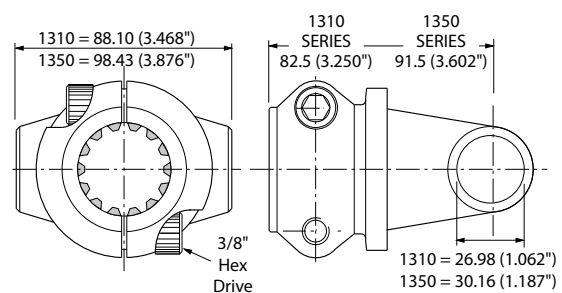

SERIES 1310 CLAMPLOCK YOKES

Pt Number	Spline	Application
84/02/13103	13T 7/8" 16/32	SAE B
84/02/13104	15T 1" 16/32	SAE BB
84/02/13105	6B 1" STRAIGHT	Orbit Motor
84/02/13110	14T 30mm 2MOD	Rexroth
84/02/13106	14T 1 1/4" 12/24	SAE C
84/02/131115	8T 32 X 36 DIN 5462	Truck PTO'S etc
84/02/13107	21T 1 3/8" 16/32	Sunstrand
84/02/13111	16T 35mm 2MOD	Rexroth
84/02/13132	17T 1 1/2" 12/24	SAE CC
84/02/13143	23T 1 1/2" 16/32	Sunstrand

SERIES 1310 INTEGRAL CLAMPLOCK YOKES

Pt Number	Bore	Application
84/13104	Spline 15T 1" 16/32	SAE BB
84/13106	Spline 14T 1 1/4" 12/24	SAE C
84/13107	Spline 21T 1 3/8" 16/32	Sunstrand
84/13124	Rnd 1 1/4" x 5/16" key	
84/13132	Spline 17T 1 1/2" 12/24	

SERIES 1350 CLAMPLOCK YOKES

Pt Number	Spline	Application
84/02/13506	14T 1 1/4" 12/24	SAE C
84/02/13508	13T 1 3/4" 8/16	SAE D-E
84/02/13533	6T 1 3/4" 6B Straight	Ag Tractor
84/02/13507	21T 1 3/8" 16/32	Sunstrand
84/02/13511	16T 35mm 2MOD	Rexroth
84/02/13532	17T 1 1/2" 12/24	SAE CC
84/02/13543	23T 1 1/2" 16/32	Sunstrand

SERIES 1350 INTEGRAL CLAMPLOCK YOKES

Pt Number	Bore	Application
84/13506	14T 1 1/4" 12/24	SAE C
84/13507	21T 1 3/8" 16/32	Sunstrand
84/13532	17T 1 1/2" 12/24	SAE CC
84/13524	Rnd 1 1/4" x 5/16" key	

CLAMPLOCK YOKE BOLT TOQUE (Nm)

Series	Min	Max
CLA	24	36
CLB	40	64
CLC	70	100

ROUND BORE KEYED SHAFT COMPANION FLANGES

ROUND BORE SERIES - 1350 & 1410 Spicer

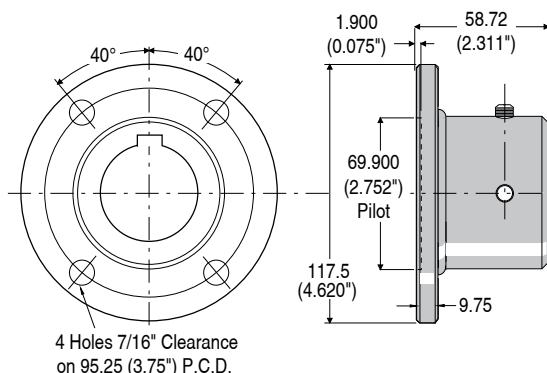

All steel construction featuring keyway and 2 set screws. Types shown are standard stock lines for 1310, 1350 and 1410 drivelines. Four hole companion flange fits Spicer type flange yokes (refer to matching yoke table on page 17). We can produce special sizes to order if quantities are sufficient for production requirements.

Bore	Keyway	Hub OD	Pt Number
1.000"	0.250"	63.5	84/F390015
1.250"	0.312"	63.5	84/F390024
1.500"	0.375"	63.5	84/F390060
1.750"	0.437"	69.5	84/F390061
0.5" pilot	-	63.0	84/F390067

To Suit Spicer flanges 1260 - 2.2.479, 1310 - 2.2.479,
1350 - 3.2.119 and 1410 - 3.2.159



UNIVERSAL JOINT DRIVE TRAIN COMPONENTS SPLINED YOKES AND COMPANION FLANGES

SPLINED CLAMPLOCK TYPE UNIVERSAL JOINT COMPANION FLANGES



Four hole companion flanges fit Spicer type flange yokes (refer to matching yoke table at bottom of page). Positive locking and positioning of drivelines to splined shafts on hydraulic pumps for 1350, 1410, 1480 and 1550 driveline PTO drives on mobile equipment such as Concrete Transit Mixers, Cranes, Harvesters, Dump Trucks, Tractors etc. May be manufactured to fit other flange yokes if required. Available to suit most common hydraulic pumps. Also available with agricultural splines.

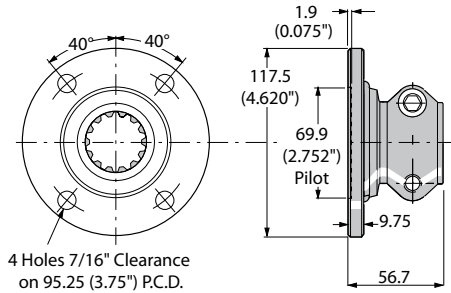

CLC & CLD SERIES - 1350 & 1410 Spicer*

Pt Number	Specifications Of Spline	Nom Spline OD	Origin Standard	No Of Teeth
84/F3CLB03	16/32 INV CL5	0.875"	IMP ANSI	13
84/F3CLC04	16/32 INV CL5	1.000"	IMP ANSI	15
84/F3CLC05	6B STRAIGHT	1.000"	Ag Tractor	6
84/F3CLC06	12/24 INV CL5	1.250"	IMP ANSI	14
84/F3CLC07	16/32 INV CL5	1.375"	IMP ANSI	21
84/F3CLC33	6B Straight	1.375"	Ag Tractor	6
84/F3CLC115	8T STRAIGHT 32x36	36mm	DIN. 5462	8
84/F3CLC32	12/24 INV CL5	1.500"	IMP ANSI	17
84/F3CLC43	16/32 INV CL5	1.500"	IMP ANSI	23
84/F3CLD08	8/16 INV CL5	1.750"	IMP ANSI	13

*To Suit Spicer flanges 1260 - 2.2.479, 1310 - 2.2.479, 1350 - 3.2.119 and 1410 - 3.2.159

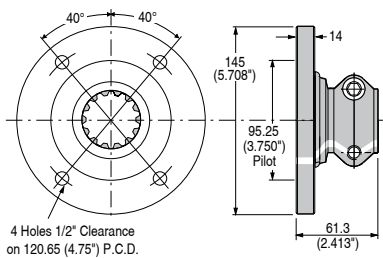

CLC & CLD SERIES - 1480 & 1550 Spicer*

Pt Number	Specifications Of Spline	Nom Spline OD	Origin Standard	No Of Teeth
84/F5CLC06	12/24 INV CL5	1.250"	IMP ANSI	14
84/F5CLC07	16/32 INV CL5	1.375"	IMP ANSI	21
84/F5CLC32	12/24 INV CL5	1.500"	IMP ANSI	17
84/F5CLD08	8/16 INV CL5	1.750"	IMP ANSI	13
84/F5CLD113	12/24 INV CL5	1.750"	IMP ANSI	20

*To Suit Spicer flanges 1410- 3.2.429, 1480 - 3.2.479 and 1550 - 4.2.669

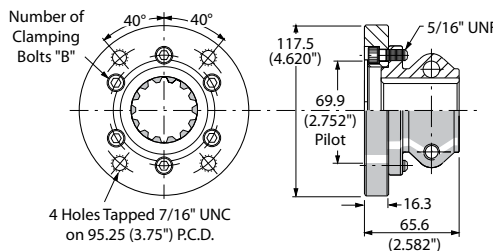

CLDA SERIES - 1350 & 1410 Spicer*

Pt Number	Specifications Of Spline	Nom Spline OD	Origin Standard	No Of "B" Teeth
84/F3CLDA36	10/20 INV CL5	1.500"	IMP ANSI	14 6
84/F3CLDA08	8/16 INV CL5	1.750"	IMP ANSI	13 6
84/F3CLDA09	16/32 INV CL5	1.750"	IMP ANSI	27 6
84/F3CLDA41	2 Module INV	40 mm	DIN 5480	18 6
84/F3CLDA42	2 Module INV	45 mm	DIN 5480	21 6

*To Suit Spicer flanges 1260 - 2.2.479, 1310 - 2.2.479, 1350 - 3.2.119 and 1410 - 3.2.159

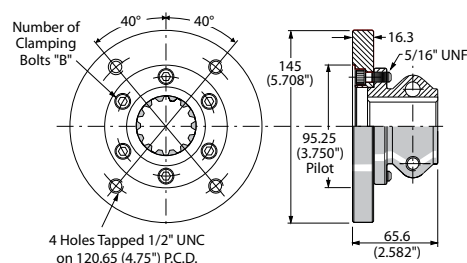

CLDA SERIES - 1480 & 1550 Spicer*

Pt Number	Specifications Of Spline	Nom Spline OD	Origin Standard	No Of "B" Teeth
84/F5CLDA36	10/20 INV CL5	1.500"	IMP ANSI	14 12
84/F5CLDA08	8/16 INV CL5	1.750"	IMP ANSI	13 12
84/F5CLDA09	16/32 INV CL5	1.750"	IMP ANSI	27 12
84/F5CLDA41	2 Module INV	40 mm	DIN 5480	18 6
84/F5CLDA42	2 Module INV	45 mm	DIN 5480	21 6

*To Suit Spicer flanges 1410- 3.2.429, 1480 - 3.2.479 and 1550 - 4.2.669

MATCHING YOKES

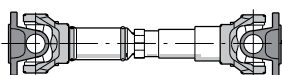

Spicer Series	Spicer Flange Yoke Number	Clamplock Companion Flange Series	
	1260	2.2.479	84/F3
	1310	2.2.479	84/F3
	1350	3.2.119	84/F3
	1410	3.2.159	84/F3
	1410	3.2.429	84/F5
	1480	3.2.479	84/F5
	1550	4.2.669	84/F5

Matching yokes listed here are included as a guide only. These are not in our product range. To purchase the matching yokes contact your driveline supplier.

Flanged adaptors to suit other Spicer sizes may be available. Contact our sales office.