

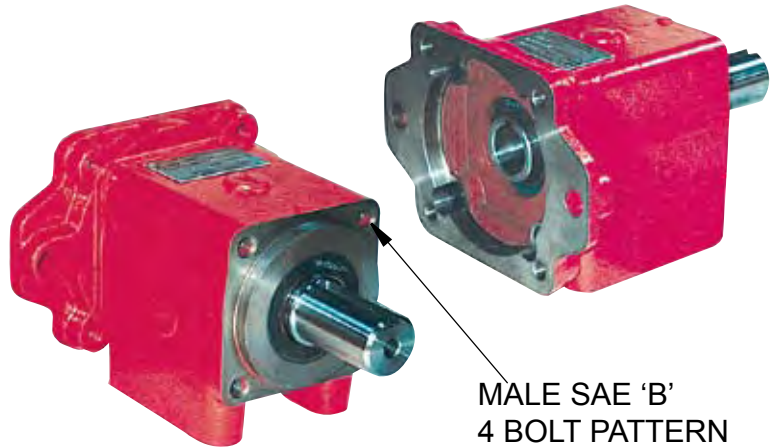

## OVERHUNG LOAD ADAPTORS FOR HYDRAULIC MOTORS

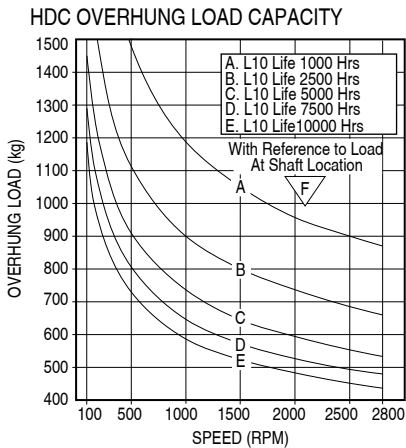

### MODEL HDC

This model has removable SAE hydraulic motor adaptors and may be supplied with SAE "A", SAE "B" or SAE "C" motor interfacing and 10 shaft size options accommodating almost any SAE Hyd motor up to SAE "C". The HDC model may also be face mounted via a set of front mount holes and pilot.

Bearings can be either Taper Roller or Cylindrical Roller types depending on the application. For applications with high axial load such as fan drives or mixer units, then Taper Roller bearings are recommended. For applications with little or no axial load such as chain or pulley drives, then Cylindrical Roller bearings can be used. The advantage of Cylindrical Roller bearings is that servicing and replacement is easier as no preloading of the new bearings is required, making field servicing of the unit more economical. External dimensions for both bearing model types are the same.

Units are usually supplied factory oil filled. Grease filling is required for vertical mount applications.

### MODEL HDC DIMENSIONS

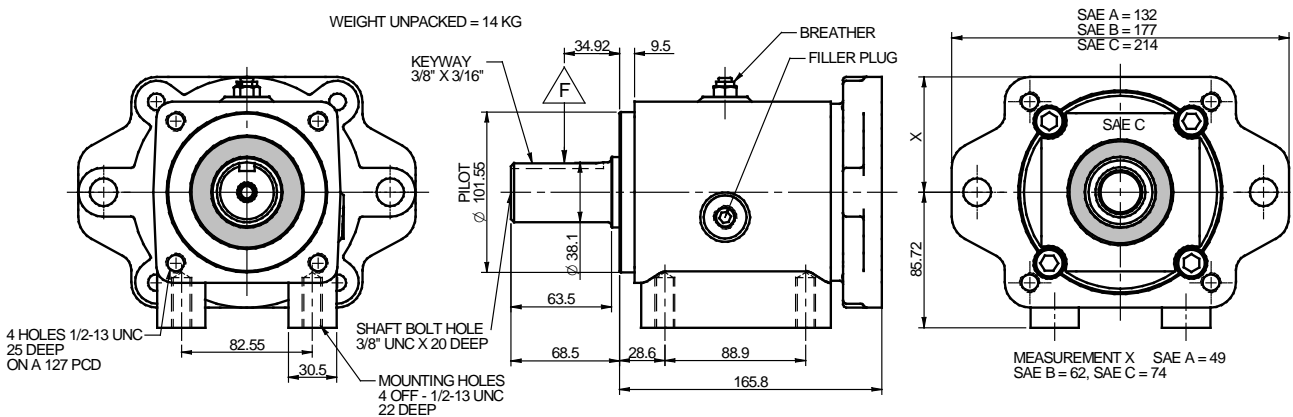

**# New !!**

HDC Ordering information

Part Number		Hyd Motor Adaptor	Hyd Motor Shaft Type	Sleeve Part No.
Cylindrical Roller	Taper Roller			
93R/15101	93/15101	SAE "A"	Spline 9T 5/8" OD 16/32 DP	64/03/20001
93R/15102	93/15102	SAE "A"	Spline 11T 3/4" OD 16/32 DP	64/03/20002
93R/15112	93/15112	SAE "A"	Round 0.625" OD 0.156" Keyway	64/03/20012
93R/15113	93/15113	SAE "A"	Round 0.75" OD 0.187" Keyway	64/03/20013
93R/15115	93/15115	SAE "A"	Round 1.000" OD 0.25" Keyway	-
93R/15203	93/15203	SAE "B"	Spline 13T 7/8 OD 16/32 DP	58/03/01698
93R/15204	93/15204	SAE "B"	Spline 15T 1" OD 16/32 DP	58/03/00714
93R/15206	93/15206	SAE "B"	Spline 14T 1.250" OD 12/24 DP	-
93R/15214	93/15214	SAE "B"	Round 0.875" OD 0.25" Keyway	-
93R/15215	93/15215	SAE "B"	Round 1.000" OD 0.25" Keyway	-
93R/15306	93/15306	SAE "C"	Spline 14T 1.250" OD 12/24 DP	-
93R/15324	93/15324	SAE "C"	Round 1.250" OD 0.312" Keyway	-