

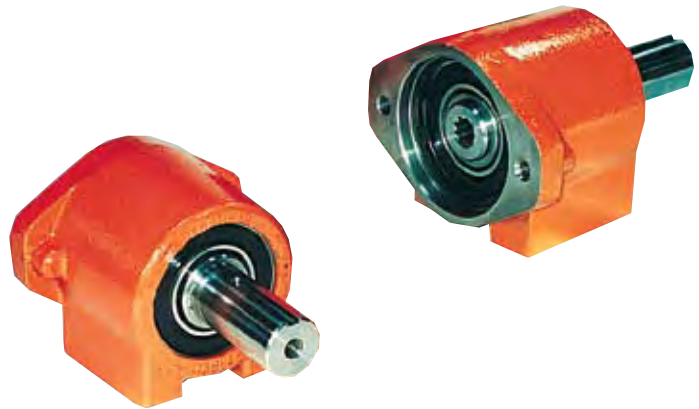

OVERHUNG LOAD ADAPTORS FOR HYDRAULIC MOTORS

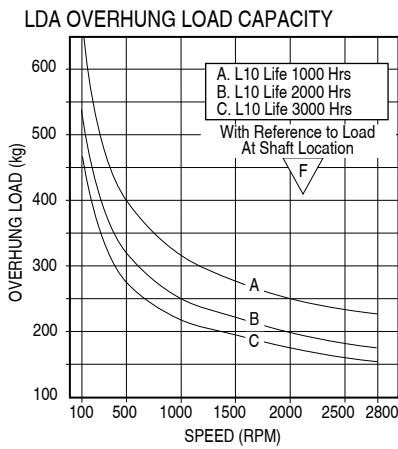

MODEL LDA

This is a low cost model with a fixed SAE "A" motor adaptor and 6 shaft size options. Bearings are sealed Ball Bearing type greased for life. Shaft options include most of those required for high speed hydraulic motors. Also included is the 1" shaft option for Charlyn, Ross TRW and Danfoss Orbit motors and 25 mm shaft to suit the SAM HYDRAULIK BG...N orbit motor.

MODEL LDA DIMENSIONS

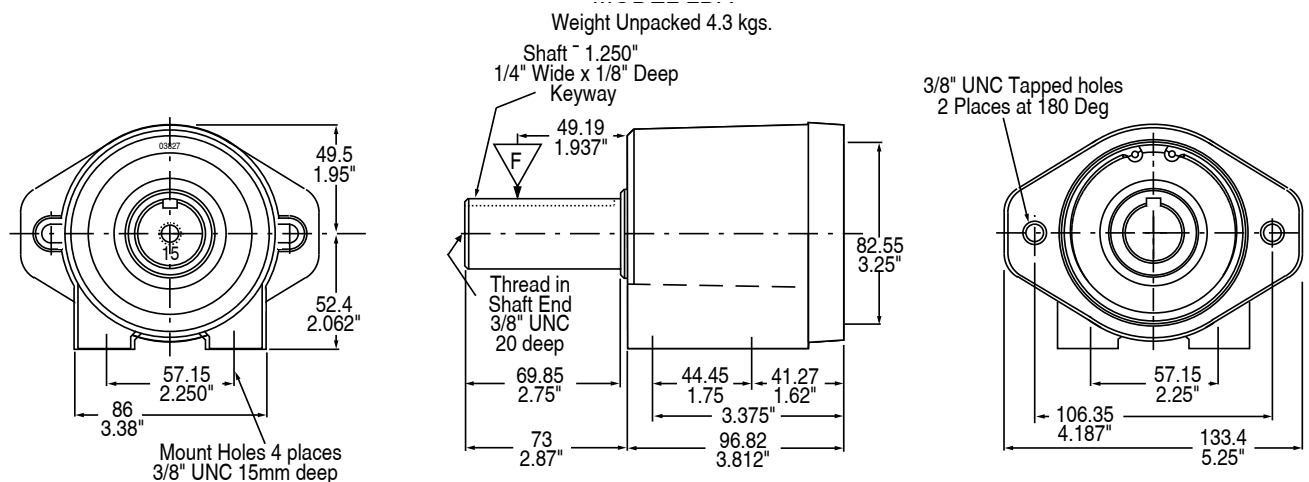

LDA Ordering information

Part Number	Hyd Motor Shaft Type	Sleeve P No.
64/125101 ^	Spline 9T 5/8" OD 16/32 DP	64/03/20001
64/125102 ^	Spline 11T 3/4" OD 16/32 DP	64/03/20002
64/125112	Round 0.625" OD 0.156" Keyway	
64/125113 ^	Round 0.750" OD 0.187" Keyway	64/03/20013
64/125114	Round 0.875" OD 0.250" Keyway	
64/125115 *	Round 1.000" OD 0.25" Keyway	
64/125126 #	Round 25mm OD 8mm Keyway	

^ Basic model 64/125115 fitted with sleeve.
For SAM HYDRAULIK-BG...N with shaft type C25.
* Directly replaces model 03-35-00043.

OVERHUNG LOAD ADAPTORS & CLUTCHES