

DIMENSIONI E CURVE CARATTERISTICHE - DIMENSION AND TYPICAL CURVES

DIMENSIONI - DIMENSIONS

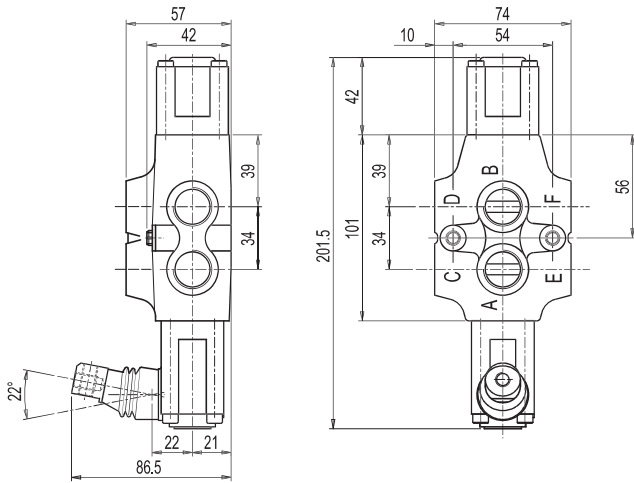

CURVA PERDITE DI CARICO - PRESSURE DROP CURVE

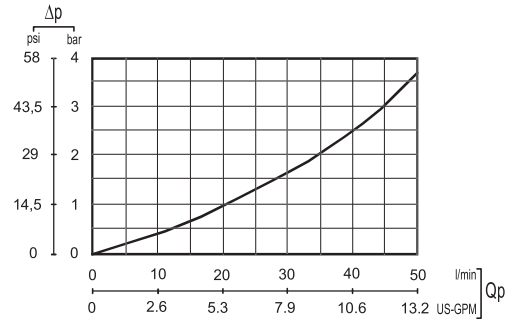

DESCRIZIONE - DESCRIPTION

Portata nominale 50 l/m
Nominal flow 50 l/m
Pressione max 350 bar
Max pressure 350 bar

SIGLA DI ORDINAZIONE
ORDERING CODE

SVM056

DIMENSIONI - DIMENSIONS

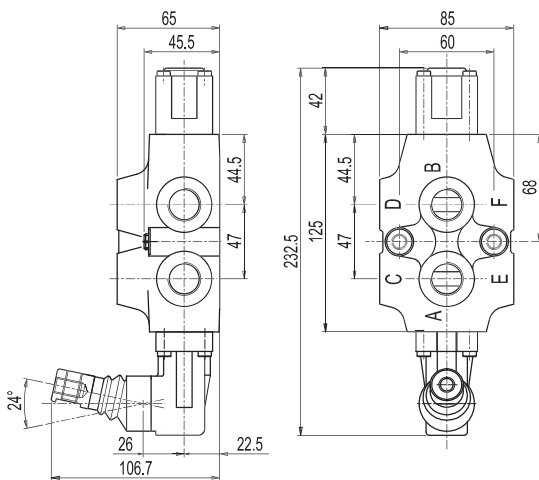

CURVA PERDITE DI CARICO - PRESSURE DROP CURVE

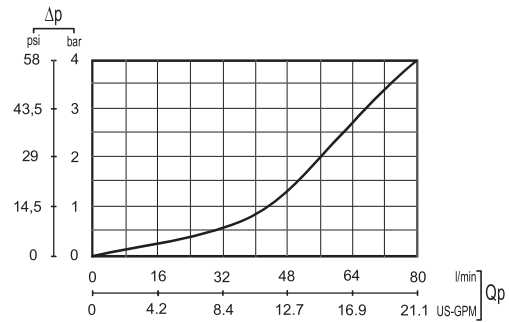

DESCRIZIONE - DESCRIPTION

Portata nominale 80 l/m
Nominal flow 80 l/m
Pressione max 350 bar
Max pressure 350 bar

SIGLA DI ORDINAZIONE
ORDERING CODE

SVM086

DIMENSIONI - DIMENSIONS

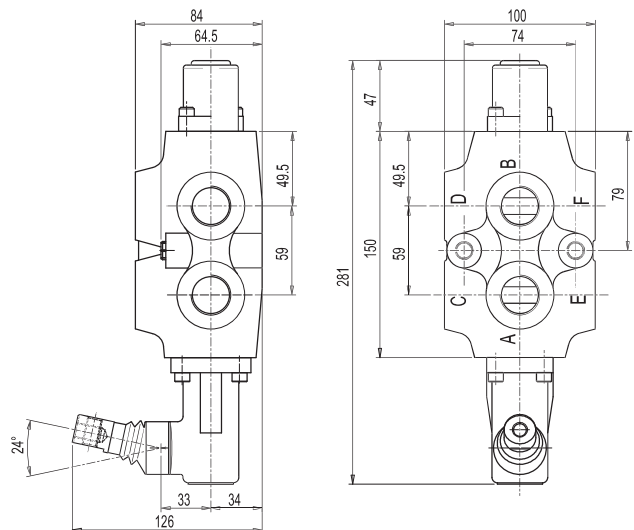

CURVA PERDITE DI CARICO - PRESSURE DROP CURVE

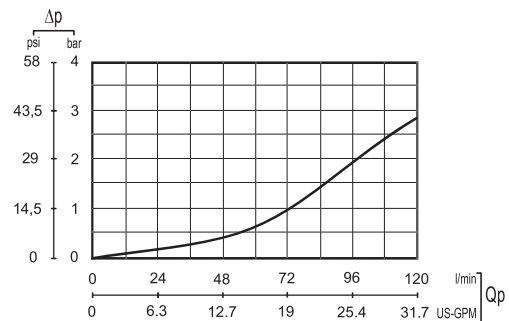

DESCRIZIONE - DESCRIPTION

Portata nominale 120 l/m
Nominal flow 120 l/m
Pressione max 350 bar
Max pressure 350 bar

SIGLA DI ORDINAZIONE
ORDERING CODE

SVM126