

KA-MT Small Flow Heatless Adsorption Dryers

Dryer Performance

Dryer Models	Dewpoint (Standard)		ISO8573-1:2010 Classification (Standard)	Dewpoint (Option 1)		ISO8573-1:2010 Classification (Option 1)	Dewpoint (Option 2)		ISO8573-1:2010 Classification (Option 2)
	°C	°F		°C	°F		°C	°F	
KA-MT 1 - 4	-40	-40	Class 2.2.2	-70	-100	Class 2.1.2	-20	-4	Class 2.3.2

ISO8573-1 Classifications when used with OIL-X pre / post filtration

Technical Data

Dryer Models	Minimum Operating Pressure		Maximum Operating Pressure		Minimum Operating Temperature		Maximum Operating Temperature		Maximum Ambient Temperature		Electrical Supply (Standard)	Electrical Supply (Optional)	Thread Type	Noise Level dB(A)
	bar g	psi g	bar g	psi g	°C	°F	°C	°F	°C	°F				
KA-MT 1 - 4	5	73	16	232	5	41	50	122	50	122	230V 1ph 50/60Hz	115V 1ph 50/60Hz	BSPP	65-86

Flow Rates

Model	Pipe Size BSPP or NPT	Inlet Flow Rate			
		L/s	m³/min	m³/hr	cfm
KA-MT 1	G¼	2	0.13	8	5
KA-MT 2	G¼	4	0.25	15	9
KA-MT 3	G¼	7	0.42	25	15
KA-MT 4	G¼	10	0.58	35	21

Stated flows are for operation at 7 bar (g) (102 psi g) with reference to 20°C, 1 bar (a), 0% relative water vapour pressure. For flows at other pressures, apply the correction factors shown below.

Product Selection & Correction Factors

For correct operation, compressed air dryers must be sized using for the maximum (summer) inlet temperature, maximum (summer) ambient temperature, minimum inlet pressure, required outlet dewpoint and maximum flow rate of the installation.

To select a dryer, first calculate the MDC (Minimum Drying Capacity) using the formula below then select a dryer from the flow rate table above with a flow rate equal to or above the MDC.

Minimum Drying Capacity = System Flow x CFMIT x CFMAT x CFMIP x CFOD

CFMIT - Correction Factor Maximum Inlet Temperature

Maximum Inlet Temperature	°C	25	30	35	40	45	50
	°F	77	86	95	104	113	122
Correction Factor		0.94	0.95	1.00	1.15	1.22	1.28

CFMAT - Correction Factor Maximum Ambient Temperature

Maximum Ambient Temperature	°C	25	30	35	40	45	50
	°F	77	86	95	104	113	122
Correction Factor		1.00	1.00	1.00	1.00	1.00	1.00

CFMIP - Correction Factor Minimum Inlet Pressure

Minimum Inlet Pressure	bar g	5	6	7	8	9	10	11	12	13	14	15	16
	psi g	73	87	100	116	131	145	160	174	189	203	218	232
Correction Factor		1.33	1.12	1.00	0.88	0.79	0.76	0.74	0.67	0.62	0.59	0.56	0.53

CFOD - Correction Factor Outlet Dewpoint

Outlet Dewpoint	°C	-20	-40	-70
	°F	-4	-40	-100
Correction Factor		1.00	1.00	2.00

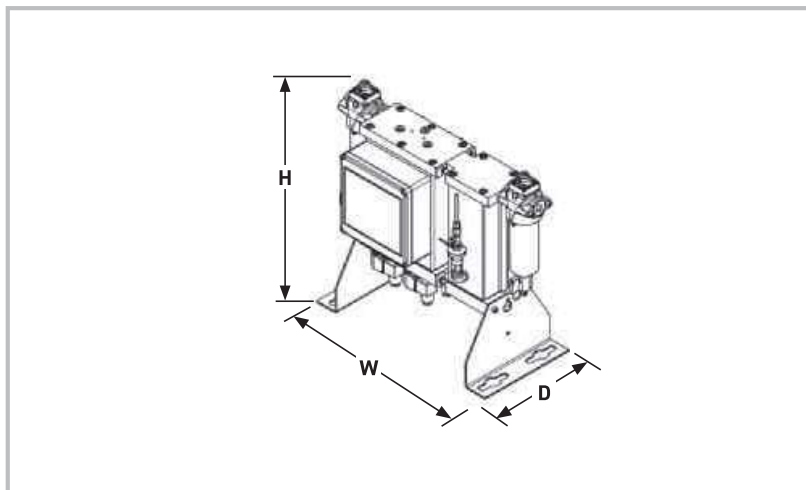

Weights & Dimensions

Model	Dimensions						Weight	
	Height (H)		Width (W)		Depth (D)			
	mm	ins	mm	ins	mm	ins	kg	lbs
KA-MT 1	400	15.75	459	18.1	216	8.5	15	33
KA-MT 2	575	22.65	459	18.1	216	8.5	20	44
KA-MT 3	825	32.5	459	18.1	216	8.5	28	62
KA-MT 4	1075	42.35	459	18.1	216	8.5	35	77

Required Filtration

Model	Pipe Size BSPP or NPT	Dryer Inlet
		General Purpose Pre-filter
KA-MT 1	¼"	AOP010A
KA-MT 2	¼"	AOP010A
KA-MT 3	¼"	AOP010A
KA-MT 4	¼"	AOP010A

Included Filtration

Dryer Inlet	Dryer Outlet		
	High Efficiency Filter	Oil Vapour Reduction Filter	General Purpose Dry Particulate Filter
AAP010A	-	AOP010A	-
AAP010A	-	AOP010A	-
AAP010A	-	AOP010A	-
AAP010A	-	AOP010A	-

Parker Catalogue Numbers 230V/1ph/50Hz-60Hz

For Dryer Model	Catalogue Number No Dewpoint Sensor	Catalogue Number With Dewpoint Sensor
KA-MT 1	K1/16DA3-G230M	K1/16DA3-G230MT
KA-MT 2	K2/16DA3-G230M	K2/16DA3-G230MT
KA-MT 3	K3/16DA3-G230M	K3/16DA3-G230MT
KA-MT 4	K4/16DA3-G230M	K4/16DA3-G230MT