

ALM2A

Parti accessorie a corredo del motore standard: linguetta (codice 522067).

Monta flangia 82-2 (A) secondo norma SAE J744c.

Le porte standard sono lavorate secondo la specifica SAE J1926/1 (ISO 11926-1)

relativa a porte filettate con tenuta O-ring.

Filetto 1/4-28 UNF profondità utile 16 mm.

Drenaggio G1/4 profondità utile 12 mm.

Accessories supplied with the standard motor: key (code 522067).

Mounting flange 82-2 (A) in compliance with SAE J744c.

Standard ports are machined in compliance with threaded port with O-ring seal in truncated housing SAE J1926/1

(ISO 11926-1).

1/4-28 UNF thread depth 16 mm.

G1/4 drain port thread depth 12 mm.

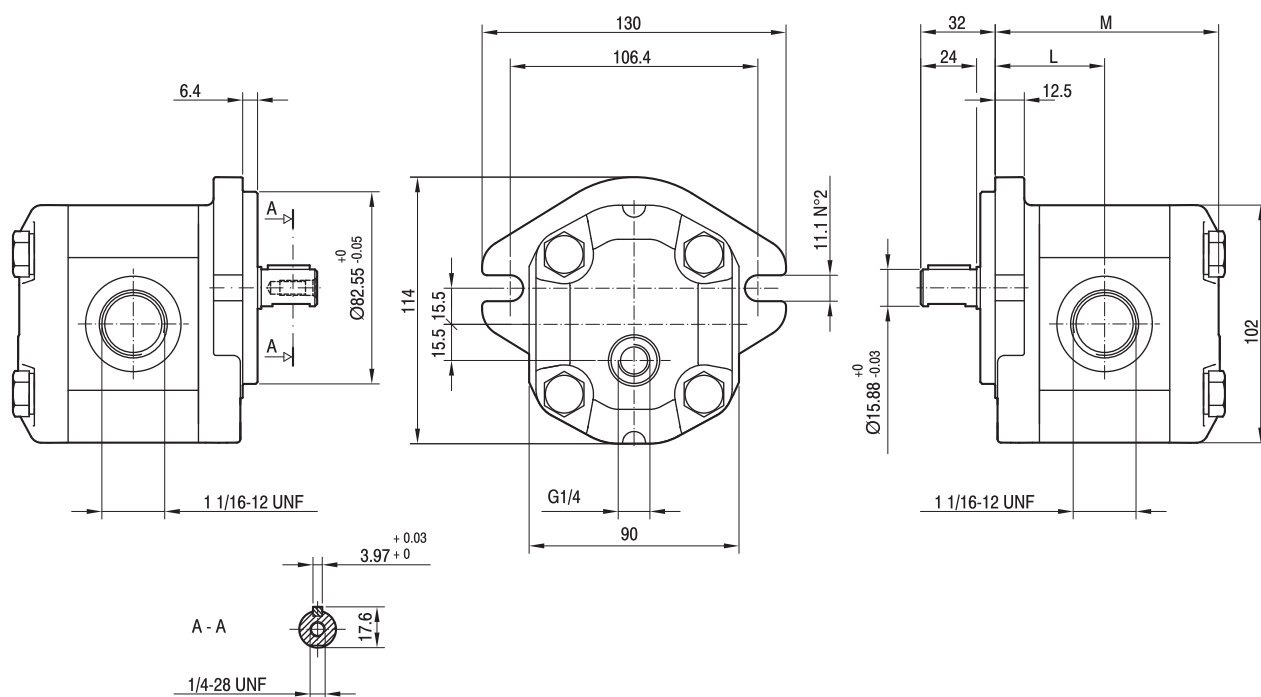

TIPO TYPE	CILINDRATA DISPLACEMENT	PORTATA α 1500 giri/min FLOW at 1500 rev/min	PRESSIONI MASSIME MAX PRESSURE			VELOCITÀ MASSIMA MAX SPEED	DIMENSIONI DIMENSIONS	
			P _I	P _C	P _P		L	M
	cm ³ /giro (cm ³ /rev)	litri/min (litres/min)	bar	bar	bar	giri/min (rpm)	mm	mm
ALM2A-R-6-E1	4,5	6,4	250	240	270	4000	45,5	93,5
ALM2A-R-9-E1	6,4	9,1	250	240	270	4000	47	96,5
ALM2A-R-10-E1	7	10	250	240	270	4000	47,5	97,5
ALM2A-R-12-E1	8,3	11,8	250	240	270	4000	48,5	99,5
ALM2A-R-13-E1	9,6	13,7	250	240	270	4000	49,5	101,5
ALM2A-R-16-E1	11,5	16,4	230	220	250	4000	51	104,5
ALM2A-R-20-E1	14,1	20,1	230	220	250	3200	53	108,5
ALM2A-R-22-E1	16,0	22,8	210	200	225	2800	54,5	111,5
ALM2A-R-25-E1	17,9	25,5	210	200	225	2500	56	114,5
ALM2A-R-30-E1	21,1	30,1	180	170	195	2200	58,5	119,5
ALM2A-R-34-E1	23,7	33,7	180	170	195	2000	60,5	123,5
ALM2A-R-37-E1	25,5	36,4	170	160	185	1800	62	126,5
ALM2A-R-40-E1	28,2	40,1	170	160	185	1800	64	130,5