

OMIT



SERIE **OMTF** SERIES
Filtri sul ritorno
Return filters

CONDIZIONI DI ESERCIZIO

Pressioni corpo filtro Pressione massima d'esercizio:
0.8 MPa (8 bar)
Pressione di scoppio:
1.0 MPa (10 bar)

Temperatura d'esercizio da -25 a +110°C

Compatibilità con i liquidi - ISO 2943 Compatibili con oli minerali tipo (HH, HM, HR, HV, HG secondo ISO 6743/4)

WORKING CONDITIONS

Filter pressure Maximum working pressure
0.8 MPa (8 bar)
Burst pressure:
1.0 MPa (10 bar)

Working temperature -25 to +110 °C

Compatibly with hydraulic fluids ISO 2943 Compatible with mineral oils type (HH, HM, HR, HV, HG (according to ISO 6743/4)

CORPO FILTRO

Testina Pressofusione di Alluminio
Contenitore OMTF09-11-17: Nylon caricato vetro
OMTF22: Acciaio con trattamento cataforesi
Attacchi ½" ÷2" BSP (altre filettature su richiesta)
Guarnizioni N: Nitrilica (Buna-N)

FILTER HOUSING

Head/Cover Die-Casting Aluminium
Filter bowl OMTF09-11-17: Glass reinforced nylon
OMTF22: Cathaphoresis treated steel
Connection Ports ½" ÷2" BSP (other sizes on request)
Seals N: Nitrile (Buna-N)

ELEMENTO FILTRANTE

Fondelli Lamiera zincata
Tubo di sostegno Ferro zincato
Materiale Filtrante Carta, Fibra Inorganica, Tela (AISI304)
Taratura
Valvola By-Pass 0.17 MPa ± 10% (1.7bar)

FILTER ELEMENT

End caps Galvanized sheet
Support tube Galvanized Steel
Filtration Media Paper, inorganic Fiberglass, Wire Mesh (AISI304)
Setting
By-Pass Valve 0.17 MPa ± 10% (1.7bar)

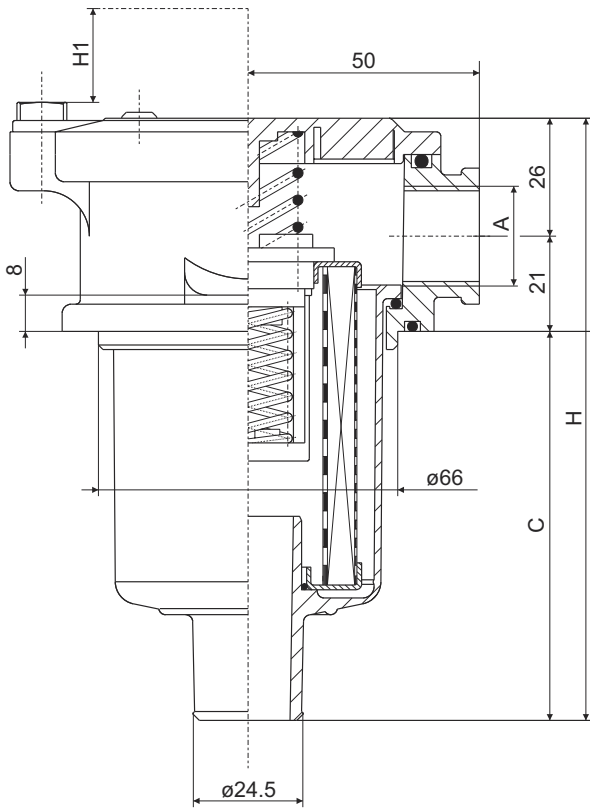

**ATTACCHI
CONNECTION PORTS**

Tipo / Type	A
	1/2" BSP

**LUNGHEZZE E PESO
LENGTHS AND WEIGHT**

Tipo / Type	C	H	H1	Peso (Kg) Weight (Kg)
1	85	132	110	0,400

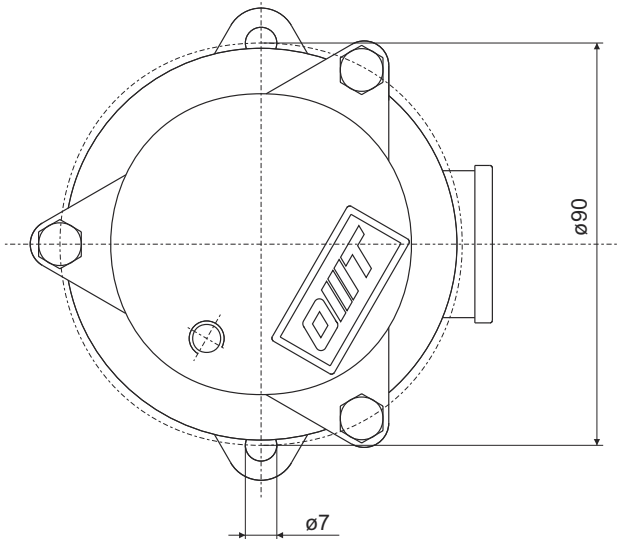

**FORATURA SERBATOIO
TANK MOUNTING PATTERN**

Serie 09 / Series 09

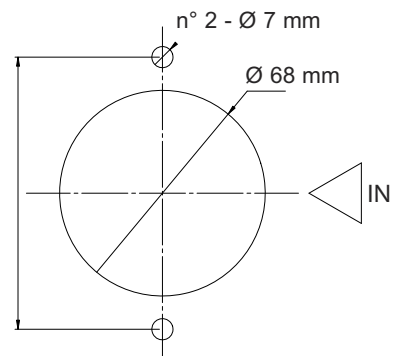

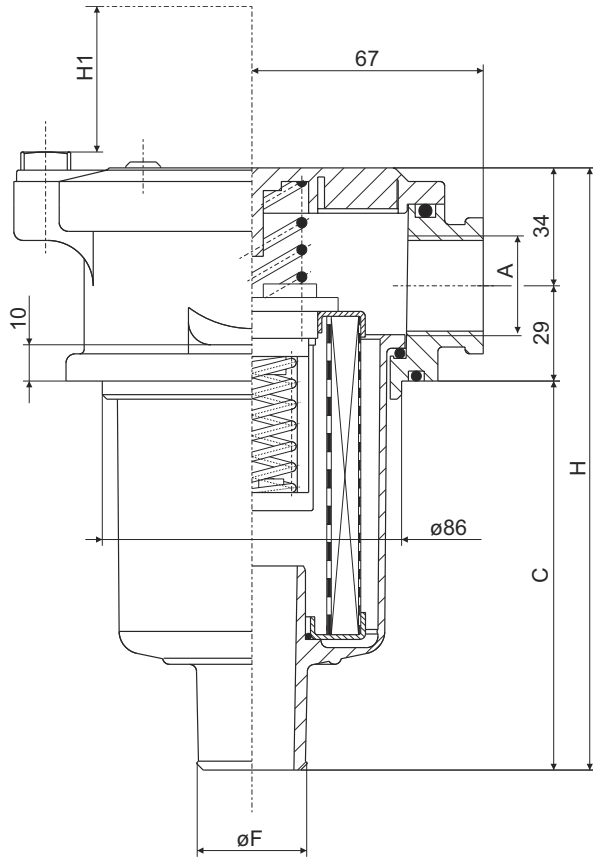

**ATTACCHI
CONNECTION PORTS**

Tipo / Type	A
	1/2" BSP
1	3/4" BSP
2	1" BSP

**LUNGHEZZE E PESO
LENGTHS AND WEIGHT**

Tipo / Type	C	H	H1	ØF	Peso (Kg) Weight (Kg)
1	92	155	130	30	0,715
2	150	213	190	30	0,770
3	232	295	270	40	0,830

**FORATURA SERBATOIO
TANK MOUNTING PATTERN**

Serie 11 / Series 11

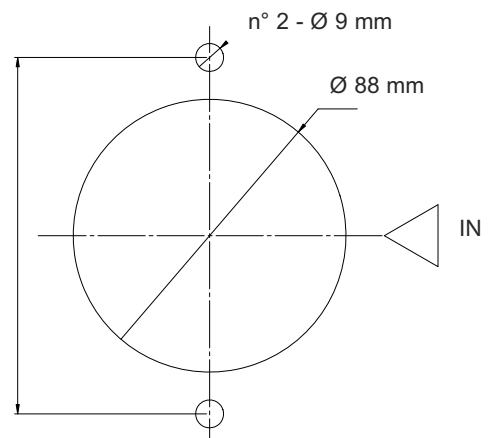
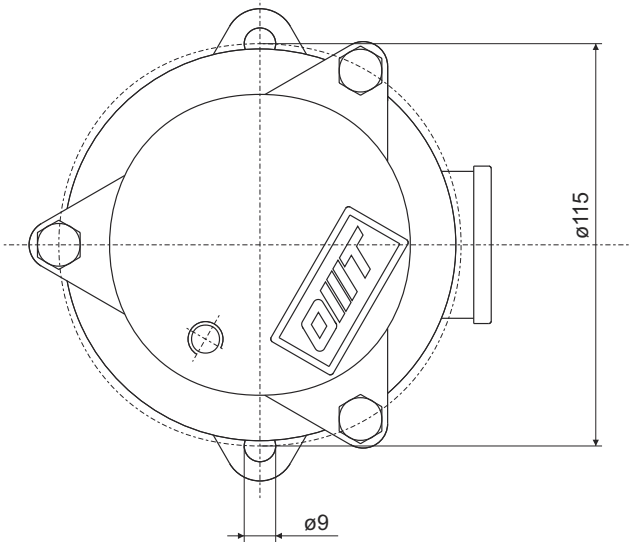

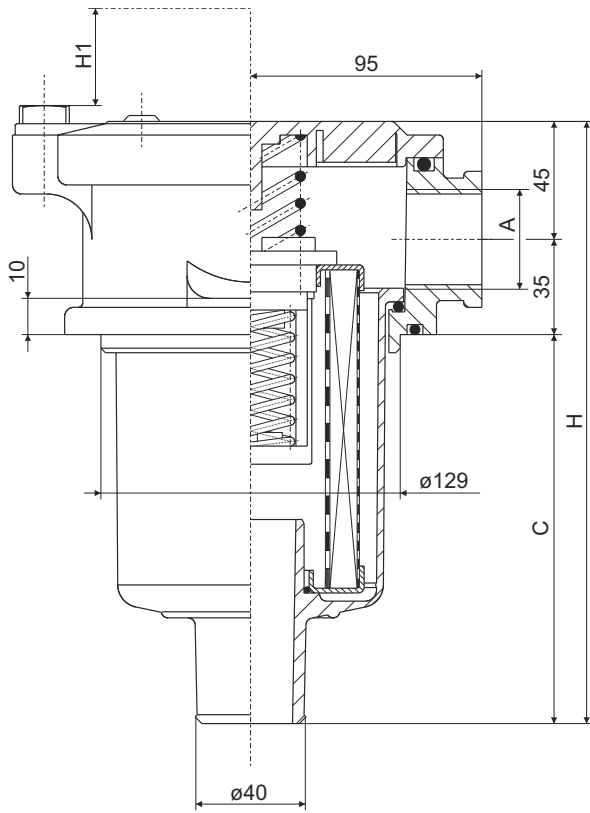

**ATTACCHI
CONNECTION PORTS**

Tipo / Type	A
	1" BSP
1	1 1/4" BSP

**LUNGHEZZE E PESO
LENGTHS AND WEIGHT**

Tipo / Type	C	H	H1	Peso (Kg) Weight (Kg)
1	244	323	255	1,940

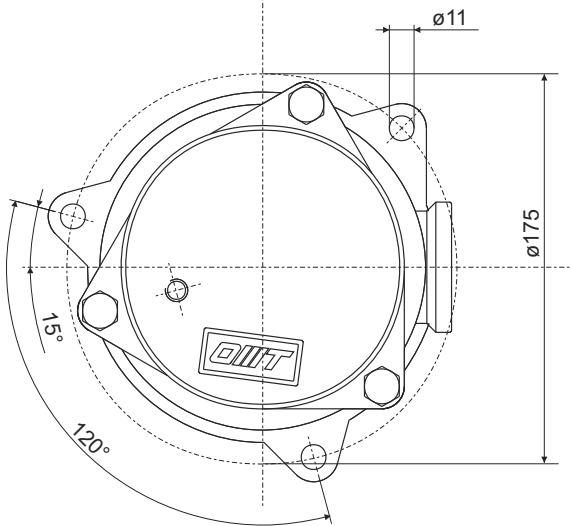

**FORATURA SERBATOIO
TANK MOUNTING PATTERN**

Serie 17 / Series 17

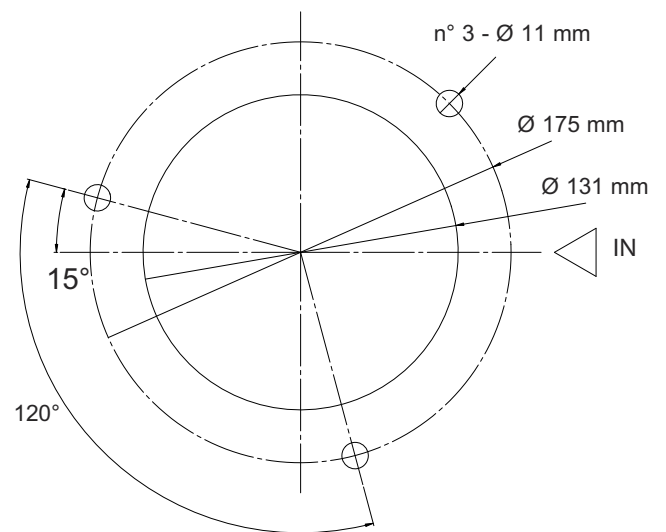

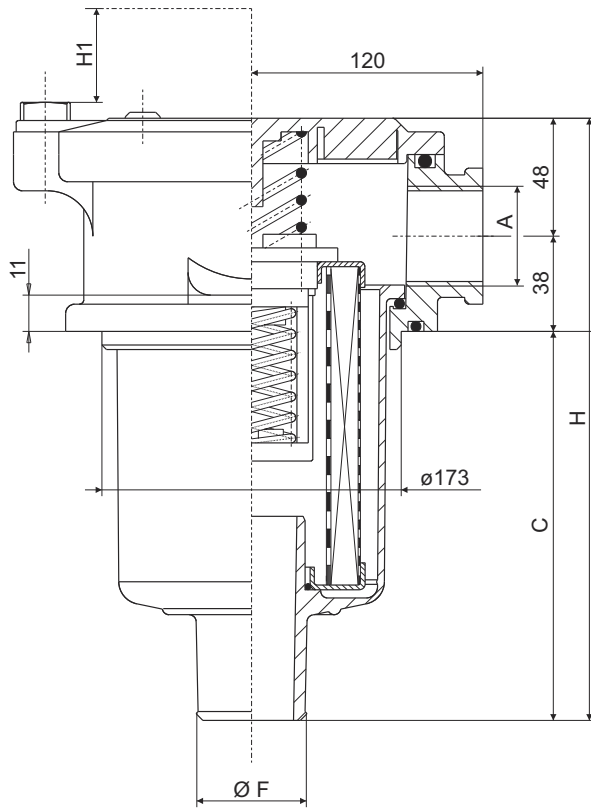

**ATTACCHI
CONNECTION PORTS**

Tipo / Type	A
	1 1/4" BSP
1	1 1/2" BSP
2	2" BSP

**LUNGHEZZE E PESO
LENGTHS AND WEIGHT**

Tipo / Type	C	H	H1	ØF	Peso (Kg) Weight (Kg)
1	176	262	210	51	3,250
2	236	322	260	51	3,800
3	236	322	260	64	3,800
4	282	368	320	64	3,900

**FORATURA SERBATOIO
TANK MOUNTING PATTERN**

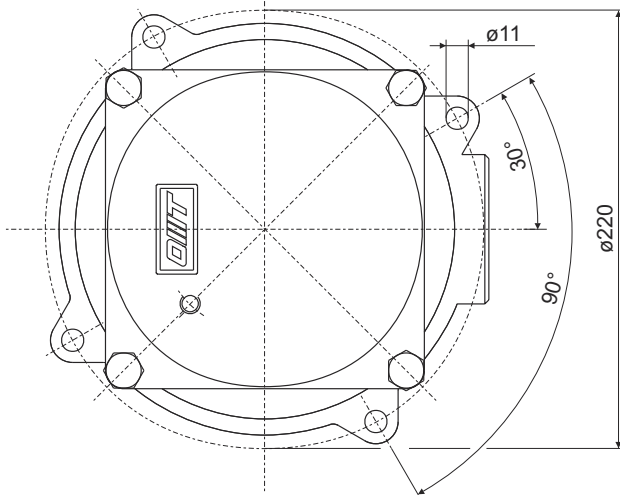

Serie 22 / Series 22

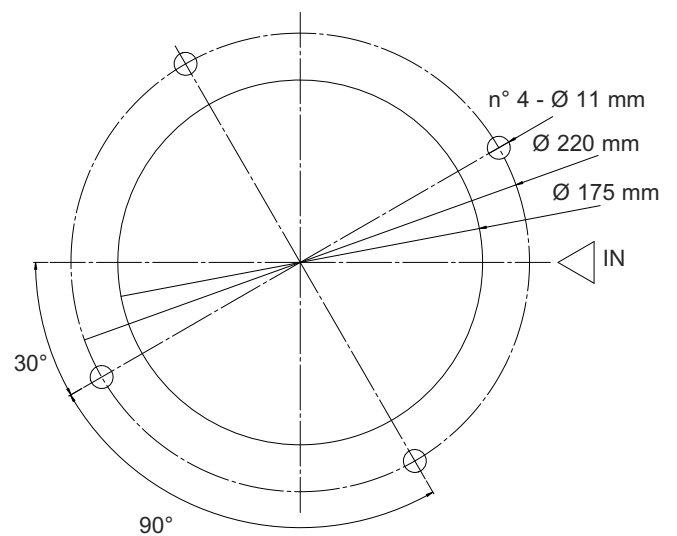

Il valore della caduta di pressione totale (Δp) si ottiene sommando, il valore Δp del corpo filtro e dell'elemento filtrante ad una data portata. Questo non deve idealmente superare 0,5 bar (7,3 psi) e non dovrebbe eccedere 1/3 del valore di taratura della valvola di by-pass.
La caduta di pressione dipende dalla viscosità dell'olio mediamente in maniera direttamente proporzionale.

The total Pressure Drop (Δp) value is obtained by adding the Δp values of filter housing and filter element at the given flow rate. This ideally should not exceed 0,5 bar (7,3 psi) and should never exceed 1/3 of the set value of the by-pass valve.
The Pressure Drop is affected by the oil viscosity in a roughly proportional way.

OMTF serie/series 09

ΔP CORPI / ΔP HOUSINGS

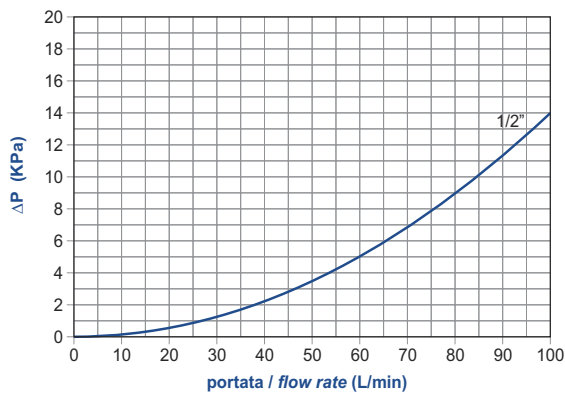

BY-PASS / BY-PASS

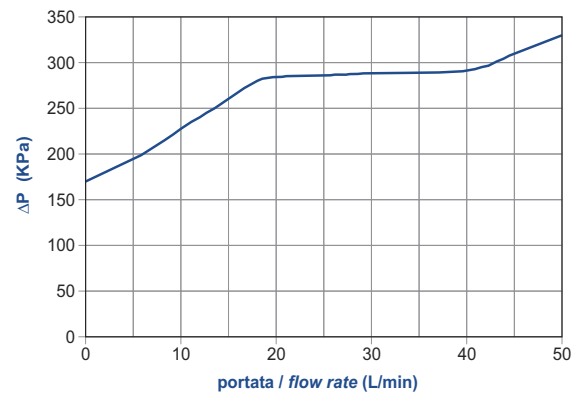

ΔP ELEMENTI

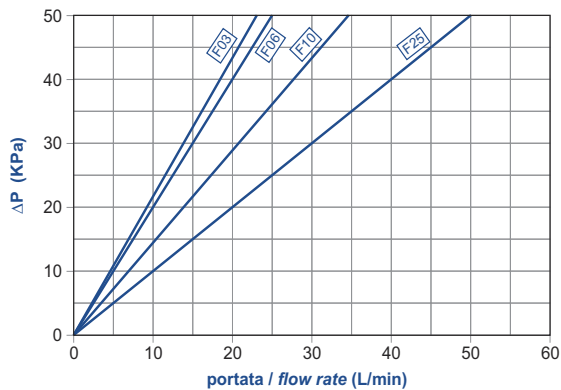

tipo CR09 1 series

ΔP ELEMENTS

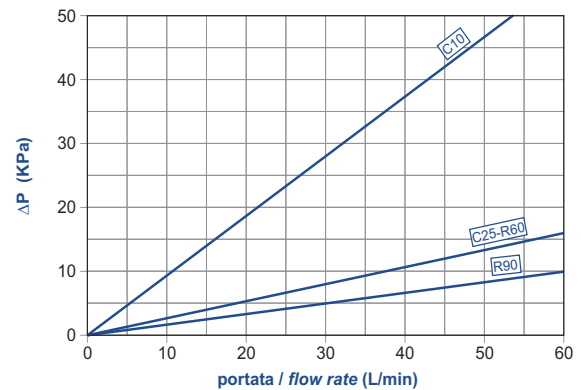

OMTF serie/series 11

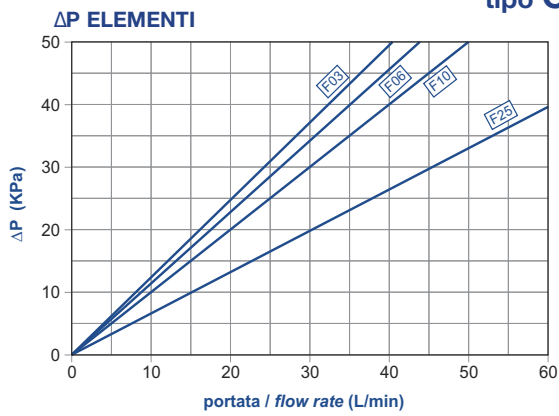
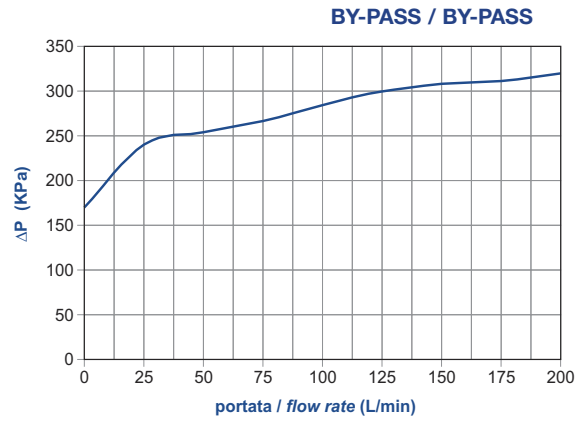
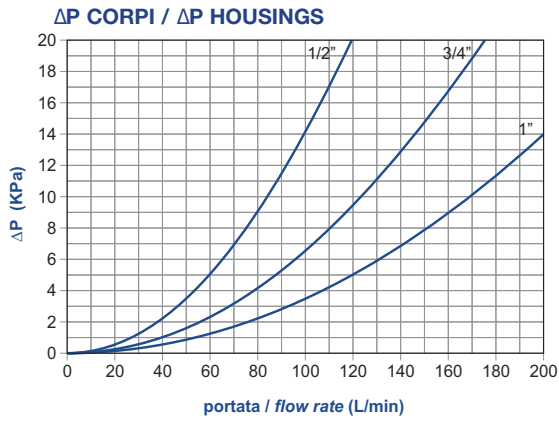

tipo CR11 1 series

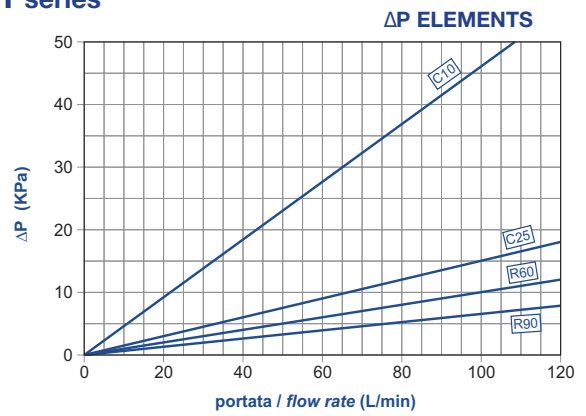

tipo CR11 2 series

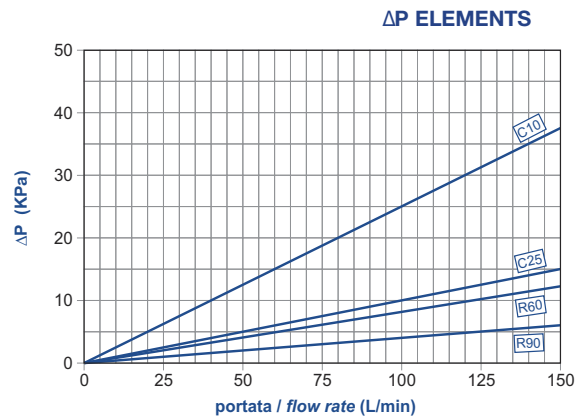
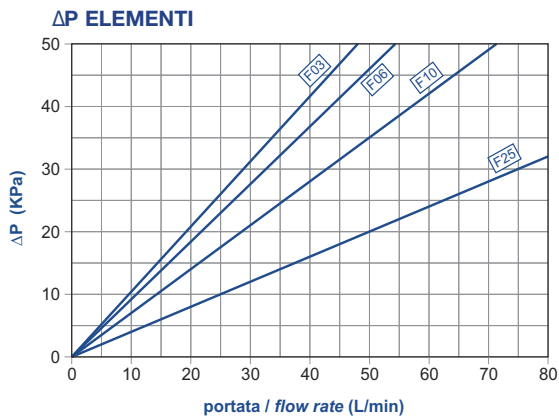

tipo CR11 3 series

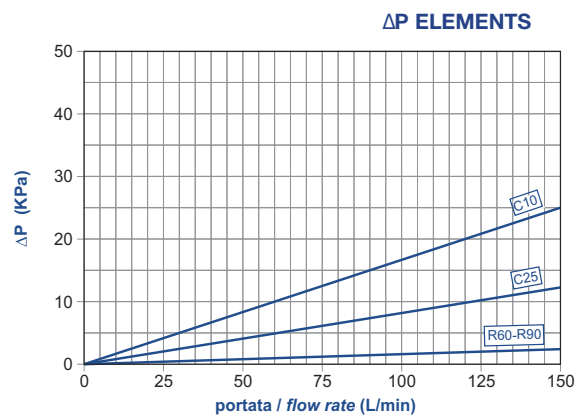
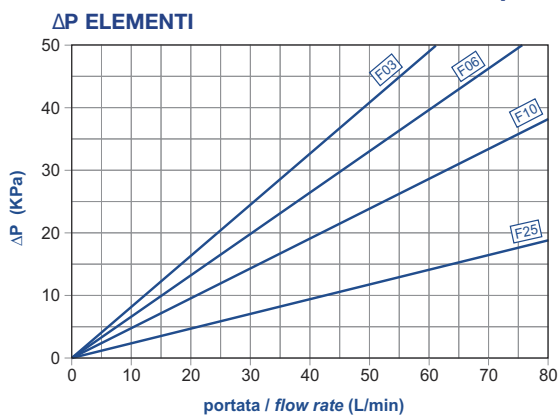

OMTF serie/series 17

ΔP CORPI / ΔP HOUSINGS

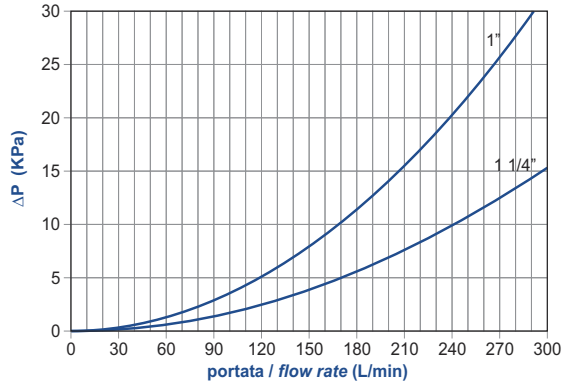

BY-PASS / BY-PASS

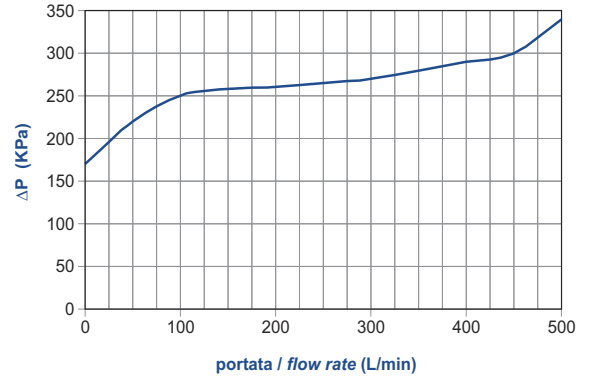

ΔP ELEMENTI

tipo CR17 1 series

ΔP ELEMENTS

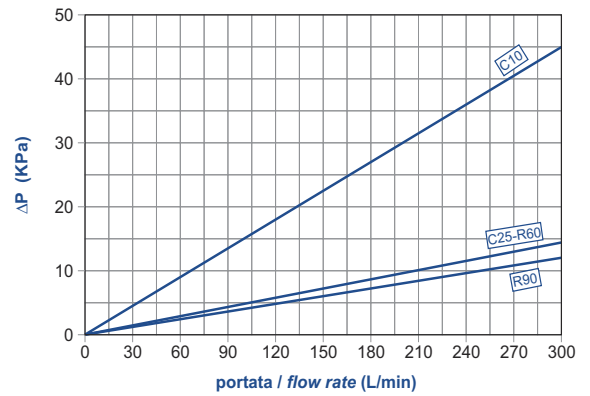
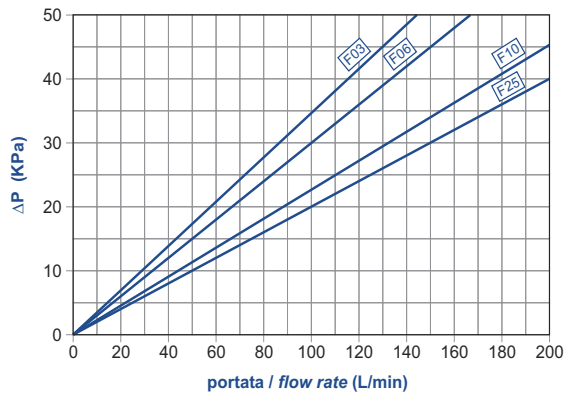

OMTF serie/series 22

ΔP CORPI / ΔP HOUSINGS

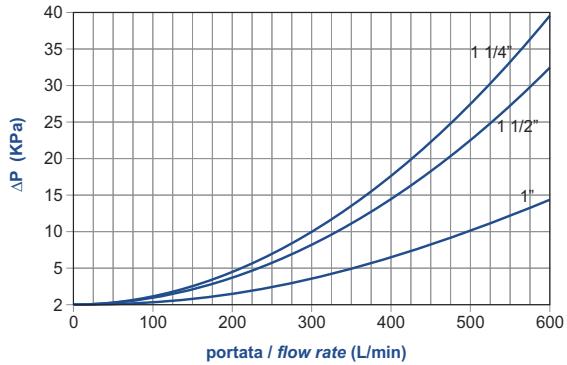

BY-PASS / BY-PASS

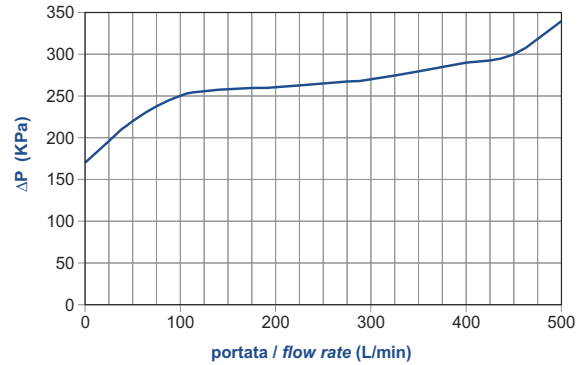

ΔP ELEMENTI

tipo CR22 1 series

ΔP ELEMENTS

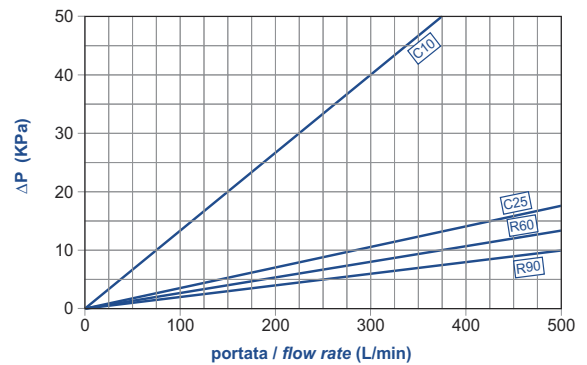
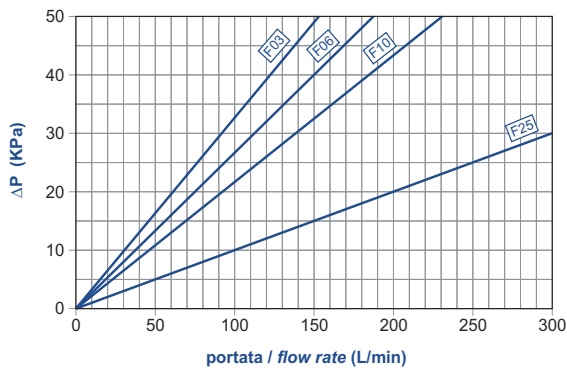

ΔP ELEMENTI

tipo CR22 2-3 series

ΔP ELEMENTS

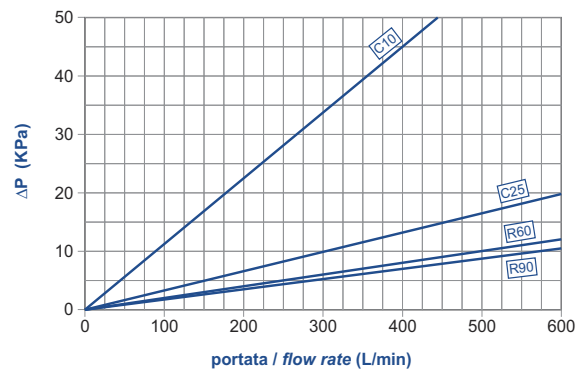
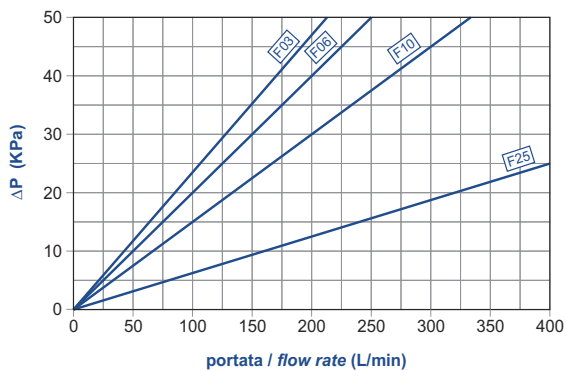

ΔP ELEMENTI

tipo CR22 4 series

ΔP ELEMENTS

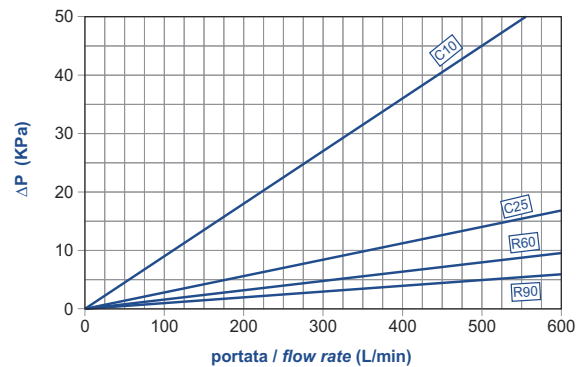
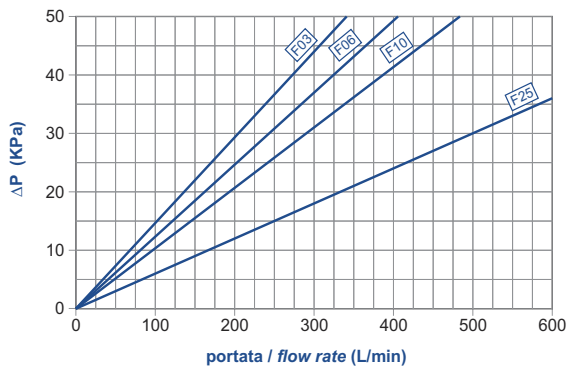

INDICATORI DI INTASAMENTO CLOGGING INDICATORS



F10 - 001

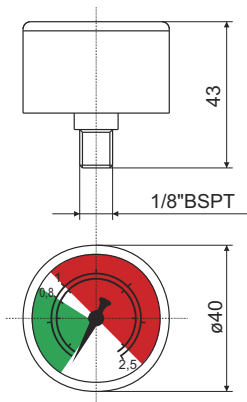

MANOMETRO
PRESSURE GAUGE

PV1

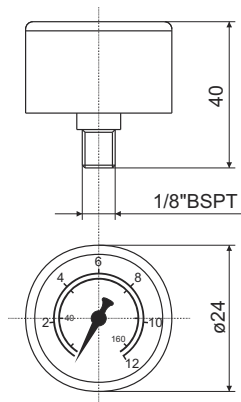

PE1 - PE2

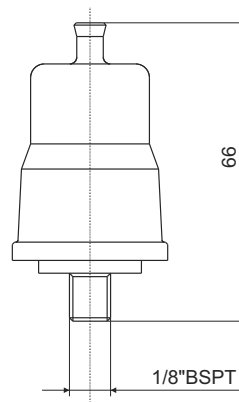

PRESSOSTATO CON
CONTATTI N.A. O N.C.
PRESSURE SWITCH WITH
CONTACTS N.O. OR N.C.

PE3

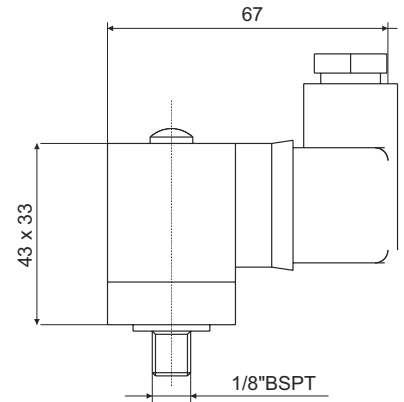

PRESSOSTATO CON
CONTATTI IN SCAMBIO
PRESSURE SWITCH
WITH CHANGEOVER
CONTACTS

NB. La caduta di pressione (Δp) attraverso il filtro cresce durante l'utilizzo. L'elemento filtrante deve essere sostituito quando l'indicatore lo segnala e prima che Δp raggiunga il valore di taratura della valvola di by-pass. Accertarsi che l'indicatore non dia un falso allarme in caso di partenza a freddo (alta viscosità dovuta a bassa temperatura).

NB. The Pressure Drop (Δp) through the filter increases during the system operation. The cartridge must be replaced when the indicator shows and before the Δp reaches the by-pass value setting. In cold start conditions a false alarm can be caused by higher oil viscosity due to low temperature.

CARATTERISTICHE TECNICHE TECHNICAL DATA

Codice Part number	Descrizione Description	Scala taratura Setting	Contatti elettrici Electrical Contacts	Tipo Type
F10-001	visivo visual	0-2,5 bar	-	Puntuale On the spot
PV1	visivo visual	0-12 bar	-	
PE1	elettrico electrical	1,3 bar	N.A. / N.O.	
PE2			N.C.	
PE3			Scambio Changeover	

CARATTERISTICHE ELETTRICHE ELECTRICAL DATA

Codice Part number	Tensione max di alimen. (V) Max feeder voltage (V)	Carico resistivo (A) Resistive load (A)	Carico induttivo (A) Inductive load (A)	Protezione (completo) Protection (complete)
PE1	C.A. 48	0,5	0,2	IP 54
PE2	C.A. 48	0,5	0,2	IP 54
PE3	C.A. 250	3	2	IP 65 DIN40050

SIMBOLOGIA / SIMBOLOGY

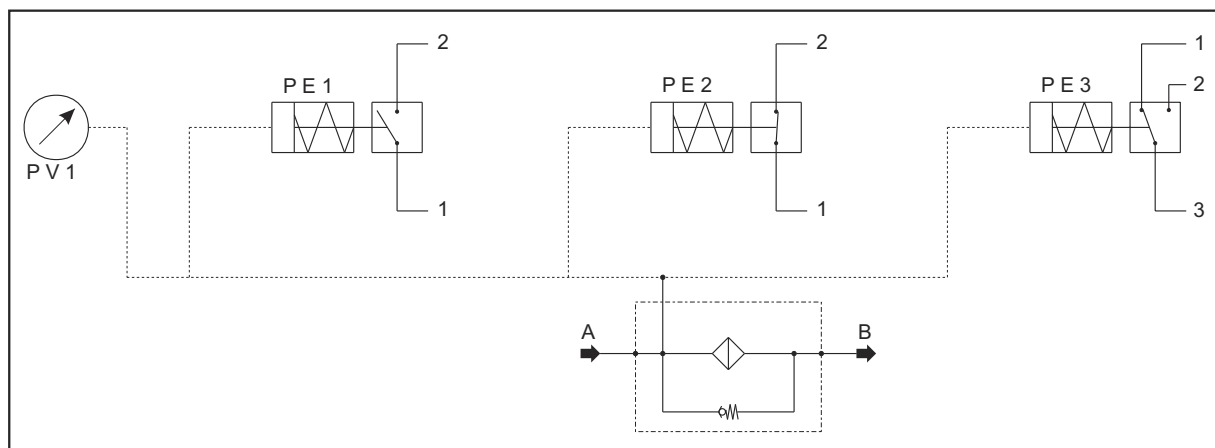

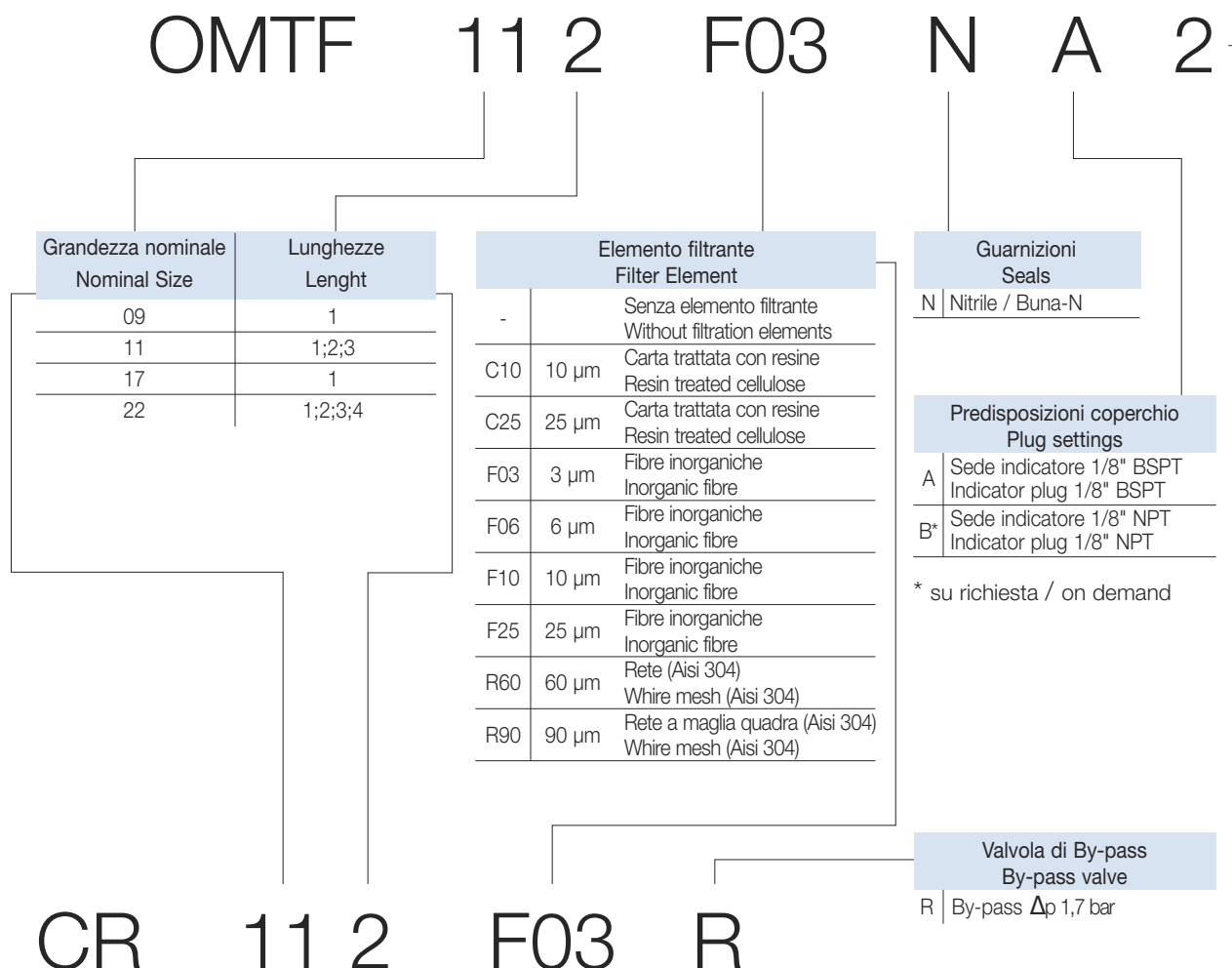

Codice per l'ordinazione dell'elemento filtrante di ricambio
Filter element code

**ATTACCHI
CONNECTION PORTS**

A	OMTF09	OMTF11	OMTF17	OMTF22
-	1/2" BSP	1/2" BSP	1" BSP	1 1/4" BSP
1		3/4" BSP	1 1/4" BSP	1 1/2" BSP
2		1" BSP		2" BSP

**CODICE KIT GUARNIZIONI
SPARE SEAL KIT P/N**

TIPO - TYPE	NBR - BUNA N
OMTF09	KIT - OMTF09
OMTF11	KIT - OMTF11
OMTF17	KIT - OMTF17
OMTF22	KIT - OMTF22

* Per l'ordinazione degli indicatori di intasamento, guardare pag. 10
* See page 10 for information how to order clogging indicators

La OMT si riserva il diritto di cessare la produzione di qualsiasi modello, di variarne le specifiche tecniche e i disegni in ogni momento, senza preavviso e senza incorrere in obblighi. Il presente catalogo annulla e sostituisce i precedenti.

OMT reserves the right to stop manufacturing any model, to modify technical specifications or drawings whenever necessary, without previous notice and without incurring obligations of any kind. This catalogue cancels and replaces the previous ones.

CONSIGLI GENERALI - GENERAL TIPPS

- | | |
|--|--|
| <ol style="list-style-type: none"> 1) Assicurarsi che il filtro sia usato secondo i parametri di pressione, temperatura e compatibilità illustrate in questo catalogo; 2) Sostituire l'elemento filtrante non appena l'indicatore attiva il segnale d'allarme alla temperatura d'esercizio. In caso nessun indicatore sia montato seguire le indicazioni dell'installatore; 3) Effettuare la manutenzione solo a sistema spento, assicurandosi che non vi sia pressione residua nel filtro; 4) Sostituire l'elemento filtrante esausto con una cartuccia OMT, verificando il codice; 5) Sostituire le guarnizioni del filtro lubrificando i filetti e avvitando con cura. | <ol style="list-style-type: none"> 1) Check the filter is working according to pressure, temperature and oil compatibility, previously described in this catalogue; 2) Replace the filter element as soon as the clogging indicator switches the alarm signal at working temperature. If no indicator is mounted, follow the instruction of the system manufacturer; 3) Perform the maintenance only when the system is switched off, ensuring that no residual pressure is present; 4) Replace the clogged filter element with a OMT cartridge, checking the part number; 5) Replace the filter gaskets, lubricating the threads and screwing with care. |
|--|--|

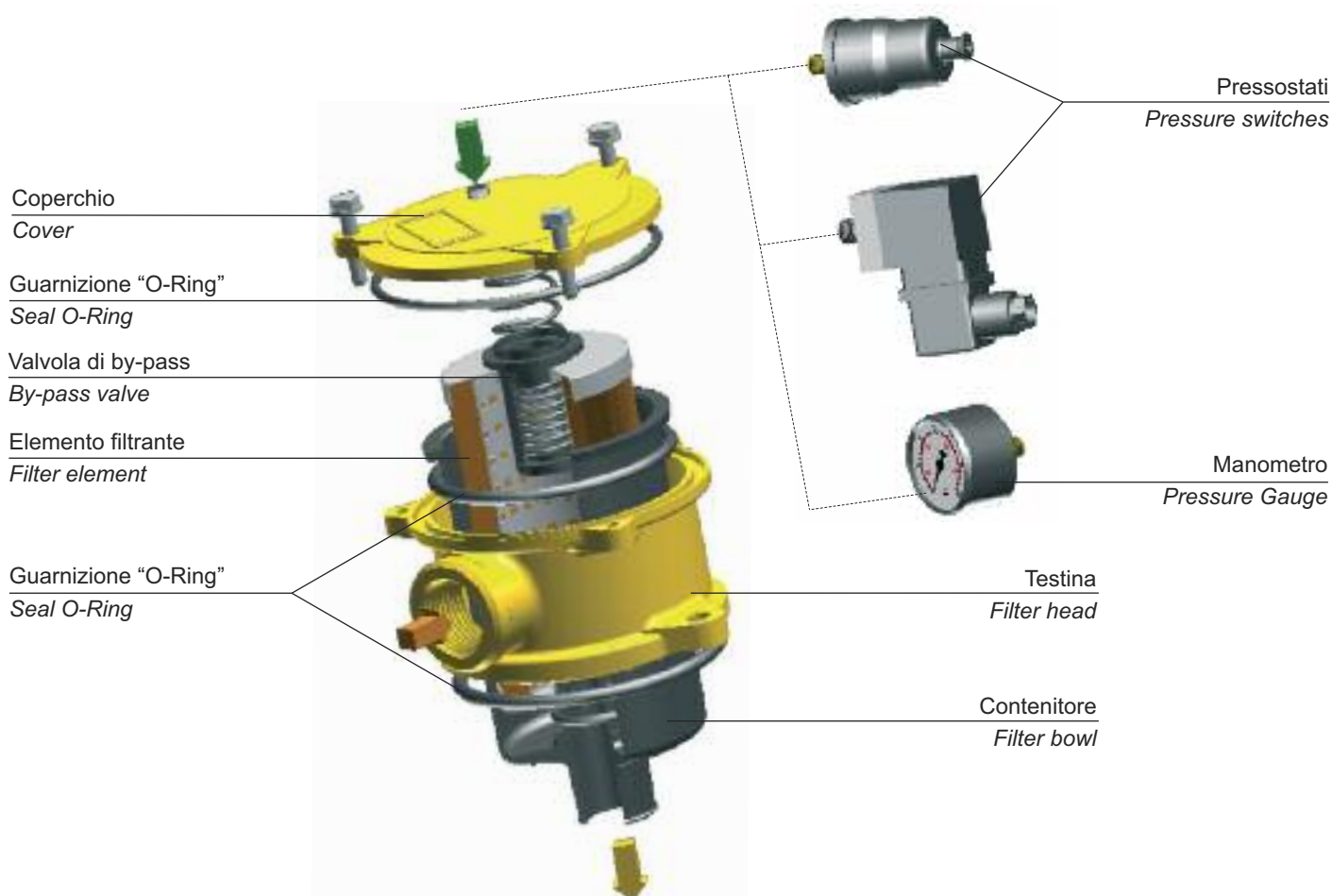

SCAMBIATORI
HEAT EXCHANGERS

FILTRI
FILTERS

ACCESSORI
ACCESSORIES

COMPONENTI
COMPONENTS

FLANGE / FLANGES
RACCORDI / COUPLINGS
BLOCCHI / MANIFOLDS

