

OIL-X IP50

50 bar Compressed Air Filters

Grade WS Water Separators

Grade AO General Purpose & Grade AA High Efficiency Coalescing & Dry Particulate Filters

Grade ACS Oil Vapour Reduction Filters (1/4" ~ 2")

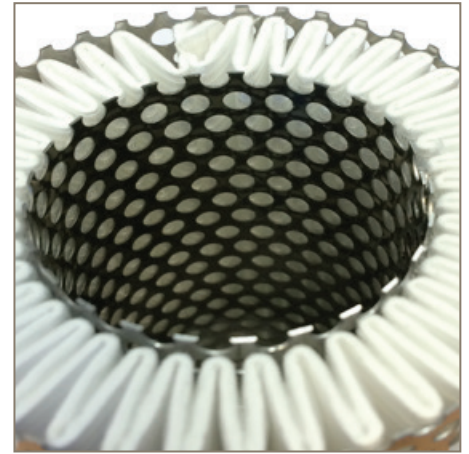

Intermediate Pressure Compressed Air Filters

Compressed air contains 10 contaminants (emanating from 4 sources) which must be treated and reduced to acceptable levels for the compressed air system to operate safely, efficiently and cost effectively.

Most industrial compressed air applications operate at pressures around 7, 10 or 13 bar g and purification equipment is typically designed around these operating pressures. There are however, applications that require higher operating pressures (which also leads to increased concentration of many contaminants).

Parker domnick hunter OIL-X IP50 Intermediate Pressure Filters

Since the introduction of the first OIL-X range, Parker domnick hunter has continued to develop both the compressed air filter and the standards governing compressed air quality.

Constantly innovated, OIL-X has become the leading technology for compressed air filtration, providing the exact balance between air quality, energy efficiency and low lifetime costs.

The Parker domnick hunter OIL-X IP50 Intermediate Pressure filter range is available in multiple filtration grades to cover all filtration requirements, including water separators, general purpose and high efficiency coalescing grades, general purpose and high efficiency dry particulate grades and an oil vapour reduction grade.



Advantages

- Meets or exceeds the requirements for delivered air quality shown in all editions of ISO8573-1, the international standard for compressed air quality
- Pleated filter element – Coalescing & Dry Particulate filter media is constructed to reduce air flow velocity and pressure loss whilst providing increased dirt holding capacity, and improved filtration efficiency
- Parker OIL-X coalescing and dry particulate filters are fully tested – Grades AO & AA in accordance with ISO12500-1 / ISO8573-2 for oil aerosol and ISO8573-4 for particulate & Grade ACS in accordance with ISO8573-5 for oil vapour
- Ideally suited for Food / Beverage / Pharmaceutical / P.E.T. applications
 - FDA Title 21 compliance
 - EC1935/2004 Exempt
- Air Quality Guarantee - The only filter range to offer a one year air quality guarantee
- Housing Guarantee - 10 year guarantee on filter housings



ENGINEERING YOUR SUCCESS.

Filtration Performance

Filtration Grade	Filter Type	Particle Reduction (inc water & oil aerosols)	Max Remaining Oil Content at 21°C (70°F)	Filtration Efficiency	Initial Dry Differential Pressure	Initial Saturated Differential Pressure	Change Element Every	Precede with Filtration Grade
WS	Liquid Oil & Water	N/A	N/A	>90%	N/A	<70 mbar (<1 psi)	N/A	N/A
AO	Coalescing & Dry Particulate	Down to 1 micron	0.5 mg/m ³ 0.5 ppm(w)	99.925%	<70 mbar (<1 psi)	<140 mbar (<2 psi)	12 months	WS
AA	Coalescing & Dry Particulate	Down to 0.01 micron	0.01 mg/m ³ 0.01 ppm(w)	99.9999%	<140 mbar (<1.5 psi)	<200 mbar (<3 psi)	12 months	AO
ACS	Oil Vapour Reduction	N/A	0.003 mg/m ³ 0.003 ppm(w)	N/A	<140 mbar (<1.5 psi)	N/A	When oil vapour is detected	A0+AA

Important Note:

Using the same filter housings as their coalescing and dry particulate counterparts in the OIL-X IP50 range, Grade ACS filter elements differ in that they utilise a deep wrapped bed of carbon cloth to adsorb oil vapour. It is important to note, in-line adsorption filter elements have a different life span compared to coalescing and dry particulate filters and require more frequent element changes.

Technical Data

Filtration Grade	Filter Models	Min Operating Pressure		Max Operating Pressure		Min Operating Temperature		Max Operating Temperature	
		bar g	psi g	bar g	psi g	°C	°F	°C	°F
AO/AA	IP50 010 ~ IP50 070	20	290	50	725	2	35	100	212
ACS	IP50 010 ~ IP50 070	20	290	50	725	2	35	30	86

Flow Rates

Model	Pipe Size	L/S	m ³ /min	m ³ /hr	cfm	Replacement Element	No.
Grade IP50 010AG X 1/4"	30	1.8	108	64	K009	Grade	1
Grade IP50 020BG X 3/8"	45	2.7	162	95	K009	Grade	1
Grade IP50 030CG X 1/2"	95	5.7	342	201	K030	Grade	1
Grade IP50 040DG X 3/4"	145	8.7	522	307	K030	Grade	1
Grade IP50 050EG X 1"	285	17.1	1026	604	K145	Grade	1
Grade IP50 060GG X 1 1/2"	465	27.9	1674	985	K145	Grade	1
Grade IP50 070HG X 2"	965	57.9	3473	2044	K220	Grade	1

Filter coding example

Grade	Model	Pipe Size	Thread	Drain Option	Incident Monitor Option
WS AO AA ACS	Cde denotes filter housing size	Letter denotes pipe size	G = BSPP	E = Automatic M = Manual	X = None
Example code					
AO	IP50 010	A	G	E	X

□ = Replace with drain type - F (Automatic) for WS water separator and A0 & AA coalescing filters or M (manual) for A0 & AA dry particulate and ACS oil vapour reduction filters.

Stated flows are for operation at 7 bar (g) (102 psi g) with reference to 20°C, 1 bar (a), 0% relative water vapour pressure. For flows at other pressures, apply the correction factors shown below.

Product Selection & Correction Factors

To correctly select a filter model, the flow rate of the filter must be adjusted for the minimum operating (inlet) pressure at the point of installation.

1. Obtain the minimum operating (inlet) pressure and maximum compressed air flow rate at the inlet of the filter.
2. Select the correction factor for minimum inlet pressure from the CFMIP table (always round down e.g. for 33 bar, use 30 bar correction factor)
3. Calculate the minimum filtration capacity. Minimum Filtration Capacity = Compressed Air Flow Rate x CFMIP
4. Using the minimum filtration capacity, select a filter model from the flow rate tables above (filter selected must have a flow rate equal to or greater than the minimum filtration capacity).

CFMIP - Correction Factor Minimum Inlet Pressure

Minimum Inlet Pressure	bar g	20	25	30	35	40	45	50
	psi g	290	362	435	507	580	652	725
Correction Factor		2.43	1.96	1.65	1.42	1.24	1.11	1.00

Filtration Tested In Accordance With

Filtration Grade	AO	AA	ACS
Filter Type	Coalescing & Dry Particulate	Coalescing & Dry Particulate	Oil Vapour Reduction
Test Methods Used	ISO8573-2 ISO8573-4 ISO12500-1	ISO8573-2 ISO8573-4 ISO12500-1	ISO8573-5
ISO12500-1 Inlet Challenge Concentration	10 mg of oil aerosol per cubic metre of compressed air	10 mg of oil aerosol per cubic metre of compressed air	0.018 mg of oil vapour per cubic metre of compressed air

Weight & Dimensions

Model	Height (H)		Width (W)		Depth (D)		Weight	
	mm	ins	mm	ins	mm	ins	kg	lbs
IP50 010	175	6.9	78	3.1	68	2.7	1.3	2.9
IP50 020	175	6.9	78	3.1	68	2.7	1.3	2.9
IP50 030	245	9.6	89	3.5	84	3.3	2.0	4.4
IP50 040	245	9.6	89	3.5	84	3.3	2.0	4.4
IP50 050	423	16.6	122	4.8	116	4.6	5.0	11.0
IP50 060	423	16.6	122	4.8	116	4.6	5.0	11.0
IP50 070	480	18.9	170	6.7	162	6.4	10.0	22.0

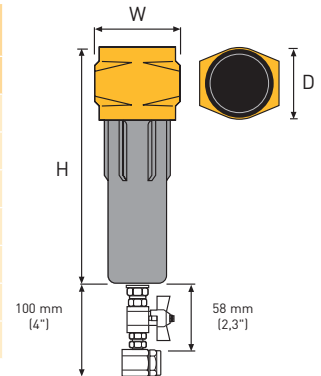

Quality Assurance / IP Rating / Pressure Vessel Approvals

Development / Manufacture	ISO 9001 / ISO 14001
Ingress Protection Rating	Not Applicable
EU	Pressure vessel approved for fluid group 2 in accordance with the Pressure Equipment Directive 2014/68/EU
USA	-
For use with Compressed Air Only	

Parker Worldwide

Europe, Middle East, Africa

AE – United Arab Emirates,
Dubai

Tel: +971 4 8127100
parker.me@parker.com

AT – Austria, St. Florian

Tel: +43 (0)7224 66201
parker.austria@parker.com

AZ – Azerbaijan, Baku

Tel: +994 50 2233 458
parker.azerbaijan@parker.com

BE/NL/LU – Benelux,

Hendrik Ido Ambacht
Tel: +31 (0)541 585 000
parker.nl@parker.com

BG – Bulgaria, Sofia

Tel: +359 2 980 1344
parker.bulgaria@parker.com

BY – Belarus, Minsk

Tel: +48 (0)22 573 24 00
parker.poland@parker.com

CH – Switzerland, Etoy

Tel: +41 (0)21 821 87 00
parker.switzerland@parker.com

CZ – Czech Republic, Klecany

Tel: +420 284 083 111
parker.czechrepublic@parker.com

DE – Germany, Kaarst

Tel: +49 (0)2131 4016 0
parker.germany@parker.com

DK – Denmark, Ballerup

Tel: +45 43 56 04 00
parker.denmark@parker.com

ES – Spain, Madrid

Tel: +34 902 330 001
parker.spain@parker.com

FI – Finland, Vantaa

Tel: +358 (0)20 753 2500
parker.finland@parker.com

FR – France, Contamine s/Arve

Tel: +33 (0)4 50 25 80 25
parker.france@parker.com

GR – Greece, Piraeus

Tel: +30 210 933 6450
parker.greece@parker.com

HU – Hungary, Budaörs

Tel: +36 23 885 470
parker.hungary@parker.com

IE – Ireland, Dublin

Tel: +353 (0)1 466 6370
parker.ireland@parker.com

IL – Israel

Tel: +39 02 45 19 21
parker.israel@parker.com

IT – Italy, Corsico (MI)

Tel: +39 02 45 19 21
parker.italy@parker.com

KZ – Kazakhstan, Almaty

Tel: +7 7273 561 000
parker.easteurope@parker.com

NO – Norway, Asker

Tel: +47 66 75 34 00
parker.norway@parker.com

PL – Poland, Warsaw

Tel: +48 (0)22 573 24 00
parker.poland@parker.com

PT – Portugal

Tel: +351 22 999 7360
parker.portugal@parker.com

RO – Romania, Bucharest

Tel: +40 21 252 1382
parker.romania@parker.com

RU – Russia, Moscow

Tel: +7 495 645-2156
parker.russia@parker.com

SE – Sweden, Spånga

Tel: +46 (0)8 59 79 50 00
parker.sweden@parker.com

SK – Slovakia, Banská Bystrica

Tel: +421 484 162 252
parker.slovakia@parker.com

SL – Slovenia, Novo Mesto

Tel: +386 7 337 6650
parker.slovenia@parker.com

TR – Turkey, Istanbul

Tel: +90 216 4997081
parker.turkey@parker.com

UA – Ukraine, Kiev

Tel: +48 (0)22 573 24 00
parker.poland@parker.com

UK – United Kingdom, Warwick

Tel: +44 (0)1926 317 878
parker.uk@parker.com

ZA – South Africa, Kempton Park

Tel: +27 (0)11 961 0700
parker.southafrica@parker.com

North America

CA – Canada, Milton, Ontario

Tel: +1 905 693 3000

US – USA, Cleveland

Tel: +1 216 896 3000

Asia Pacific

AU – Australia, Castle Hill

Tel: +61 (0)2-9634 7777

CN – China, Shanghai

Tel: +86 21 2899 5000

HK – Hong Kong

Tel: +852 2428 8008

IN – India, Mumbai

Tel: +91 22 6513 7081-85

JP – Japan, Tokyo

Tel: +81 (0)3 6408 3901

KR – South Korea, Seoul

Tel: +82 2 559 0400

MY – Malaysia, Shah Alam

Tel: +60 3 7849 0800

NZ – New Zealand, Mt Wellington

Tel: +64 9 574 1744

SG – Singapore

Tel: +65 6887 6300

TH – Thailand, Bangkok

Tel: +662 186 7000

TW – Taiwan, Taipei

Tel: +886 2 2298 8987

South America

AR – Argentina, Buenos Aires

Tel: +54 3327 44 4129

BR – Brazil, Sao Jose dos Campos

Tel: +55 800 727 5374

CL – Chile, Santiago

Tel: +56 2 623 1216

MX – Mexico, Toluca

Tel: +52 72 2275 4200



EMEA Product Information Centre

Free phone: 00 800 27 27 5374

(from AT, BE, CH, CZ, DE, DK, EE, ES, FI, FR, IE, IL, IS, IT, LU, MT, NL, NO, PL, PT, RU, SE, SK, UK, ZA)

US Product Information Centre

Toll-free number: 1-800-27 27 537

www.parker.com/gsf