

General Description

Series D1VL directional control valves are high-performance, 4-chamber, direct operated, lever controlled, 4-way valves. They are available in 2 or 3-position and conform to NFPA's D03, CETOP 3 mounting patterns.

Features

- Spring return or detent styles available
- Heavy duty handle design

Specifications

Mounting Pattern	NFPA D03, CETOP 3, NG 6
Maximum Pressure	Operating: 345 Bar (5000 PSI) Tank Line: 34 Bar (500 PSI)
Maximum Flow	See Reference Data
Force Required to Shift Lever Operator	25 N (5.6 lbs)

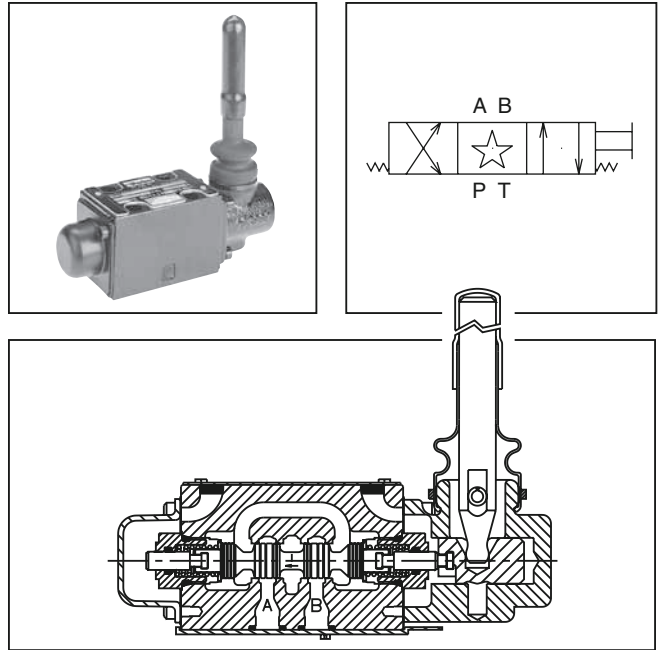

Dimensions

Inch equivalents for millimeter dimensions are shown in (**)

Lever Operated D1VL

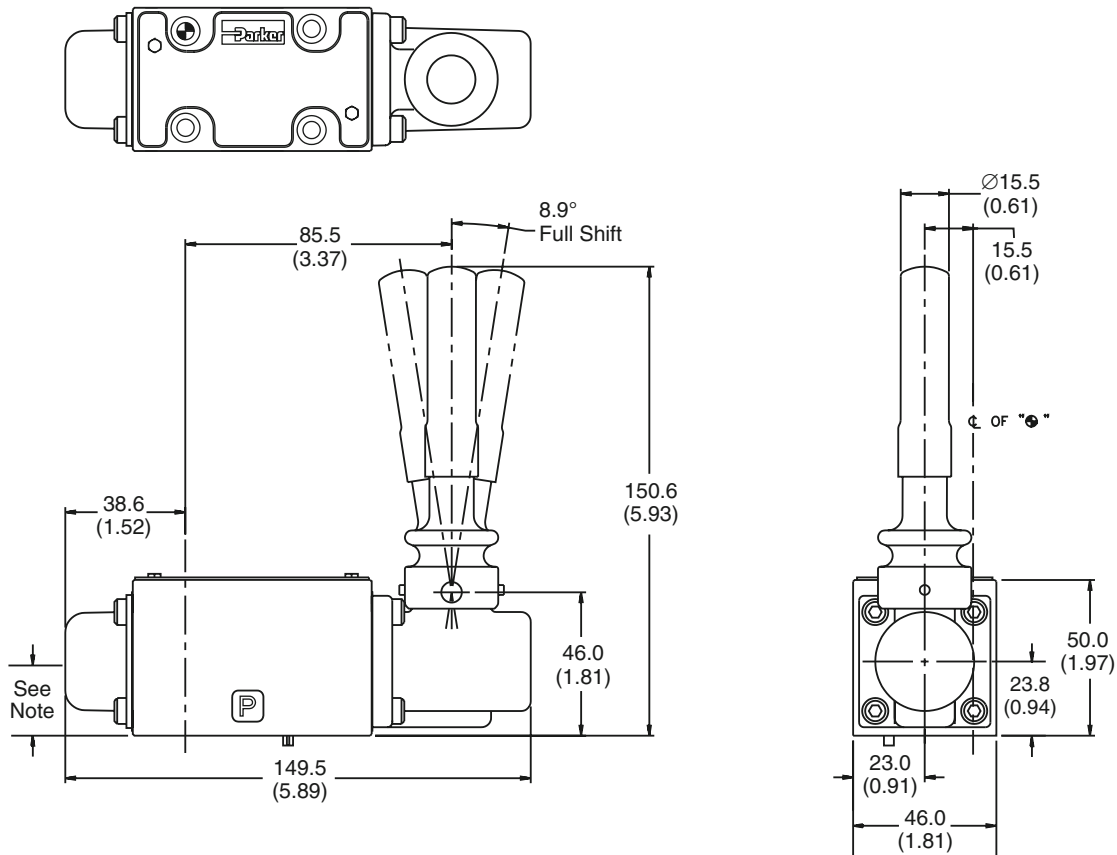

Note: 22.0 mm (0.87") from bottom of bolt hole counterbore to bottom of valve.

D1.indd, dd

A

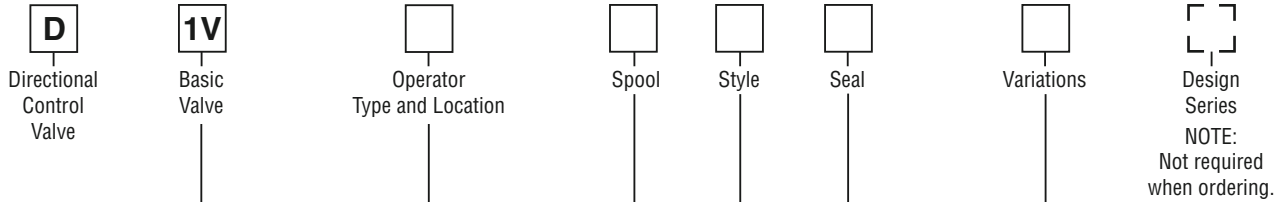

Code	Description
Omit	Standard
P10*	Monitor Switch

* Not available on C,D or N styles. Not CE or CSA approved.

Operator Location (A or B Port End)		
Code	Operator Type	For Valve Style
		B C D E H K N
L	Lever (Standard)	B B B A B B B
LB	Lever (Alternate)	A A A N/A A N/A A

Code	Description
N	Nitrile
V	Fluorocarbon

Code	Symbol
001	
002	
004	
008*	
009†	
081*	
082	

* 008 and 081 spools have closed crossover.
 † 009 has open crossover.

Code	Description	Symbol
B	Two position, spring offset. P to A and B to T in offset position.	
C	Three position, spring centered.	
D	Two position, detent.	
E	Two position, spring centered. P to B and A to T in shifted position.	
H	Two position, spring offset. P to B and A to T in offset position.	
K	Two position, spring centered. P to A and B to T in shifted position.	
N	Three position, detent.	

This condition varies with spool code.

Valve schematic symbols are per NFPA/ANSI standards, providing flow P to A when energizing operator A. Note flow paths reverse sides for #008 and #009 spools in three position valves.

Valve Weight: 1.60 kg (3.5 lbs.)
Standard Bolt Kit: BK209 10-24x1.25
Metric Bolt Kit: BKM209 M5-0.8x30mm Grade 8 bolts required

Seal Kit:
 Nitrile SKD1VL
 Fluorocarbon SKD1VLV

Bold: Designates Tier I products and options.

Non-Bold: Designates Tier II products and options. These products will have longer lead times.