

**Model No.**

**T7B or T7BS - B10 - 1 R 00 - A 1 - M0 - ..**

**T7B series - 100 A2 HW**  
ISO 2 bolts 3019-2 mounting flange

**T7BS series - SAE B 2 bolts**  
J744 mounting flange

**Displacement**

Volumetric displacement (ml/rev.)  
 B02 = 5,8    B07 = 22,5    B11 = 35,0  
 B03 = 9,8    B08 = 24,9    B12 = 41,0  
 B04 = 12,8    B09 = 28,0    B14 = 45,0  
 B05 = 15,9    B10 = 31,8    B15 = 50,0  
 B06 = 19,8

**Type of shaft T7B - T7BS**  
2 = keyed (ISO R775)

**Type of shaft T7BS**  
 1 = keyed (SAE B) Ø 22,2  
 3 = splined (SAE B) 13 teeth  
 4 = splined (SAE BB) 15 teeth

**Modifications**

**Mounting w/connection variables**  
4 bolts SAE flange J518

	T7B-T7BS		T7BS	
	Metric thread	UNC thread	00	01
P	1"	3/4"	1"	3/4"
S	1.1/2"			

**Seal class**

1 = S1 BUNA N - 0,7 bar max. (for mineral oil)  
 4 = S4 EPDM - 0,7 bar max. (for fire resistant fluids)  
 5 = S5 VITON® - 0,7 bar max. (for mineral oil and fire resistant fluids)

**Design letter**

**Porting combination**

00 = standard

**Direction of rotation (shaft end view)**

R = Clockwise  
 L = Counter-clockwise

P = Pressure port  
 S = Suction port

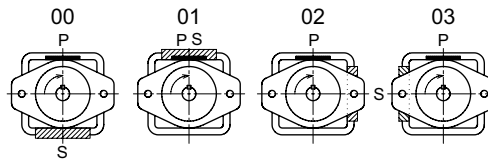

**INTERNAL LEAKAGE (TYPICAL)**

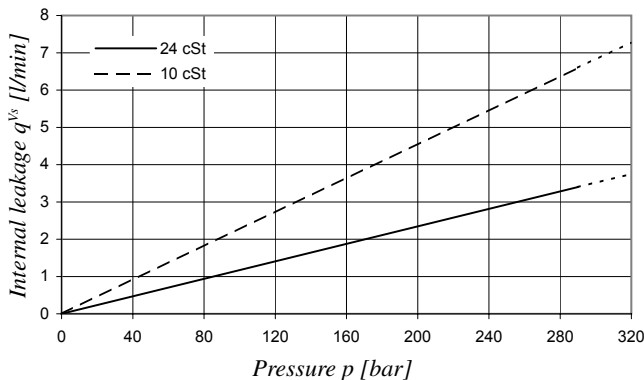

Do not operate pump more than 5 seconds at any speed or viscosity if internal leakage is higher than 50% of theoretical flow.

**NOISE LEVEL (TYPICAL) - T7B - B10**

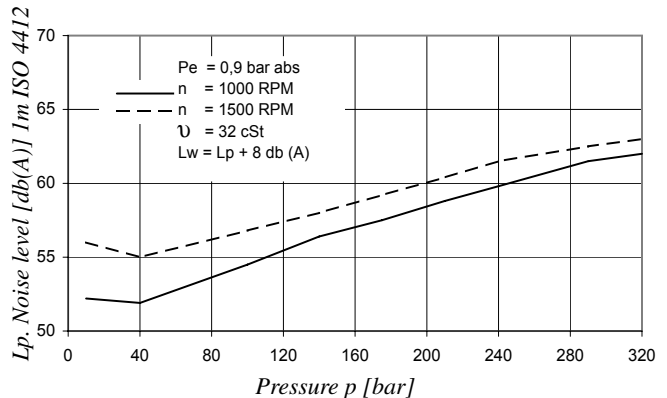

**POWER LOSS HYDROMECHANICAL (TYPICAL)**

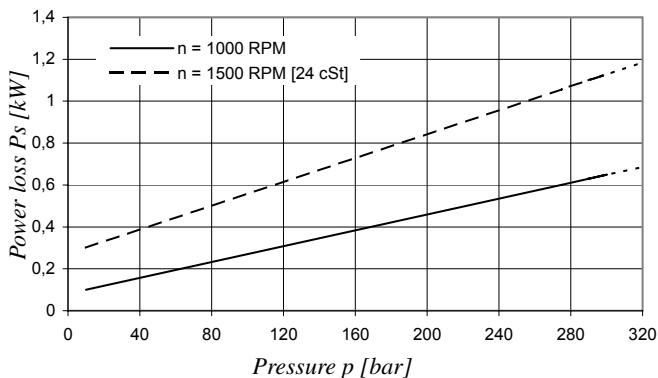

**PERMISSIBLE RADIAL LOAD**

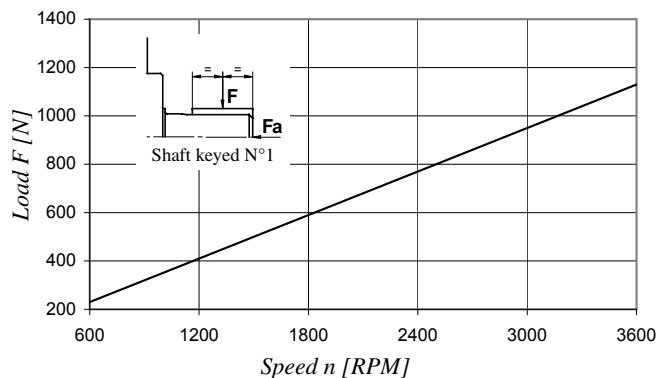

Maximum permissible axial load Fa = 800 N

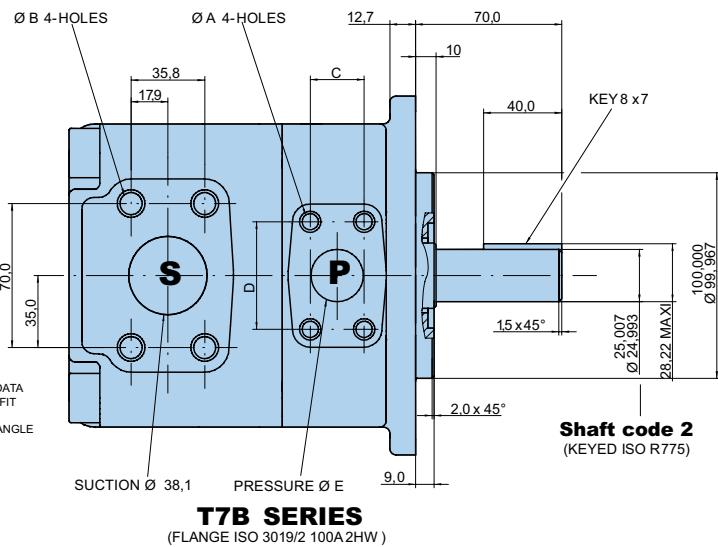
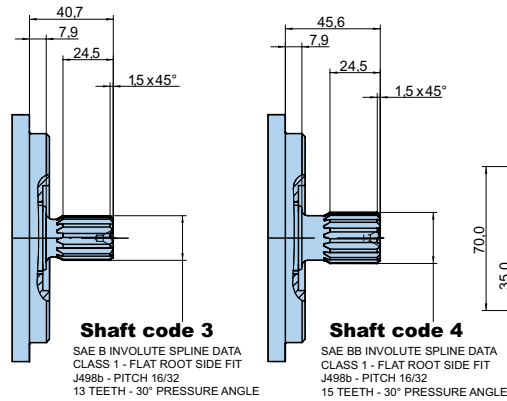
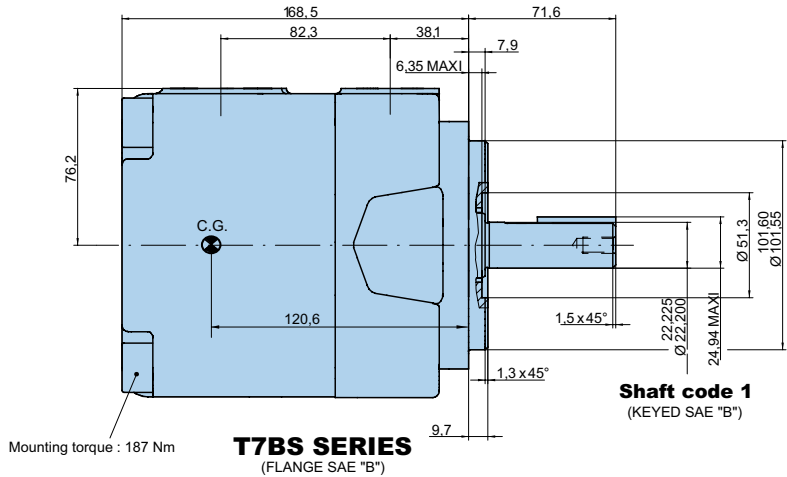
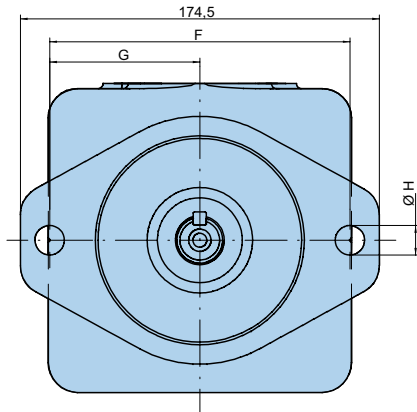

Model	T7B		T7BS	
	M0	M1	00	01
Ø A	M10 x 19 deep		3/8"-16 UNC x 19 deep	
Ø B	M12 x 22,4 deep		1/2"-13 UNC x 22,4 deep	
C	26,20	22,25	26,20	22,25
D	52,4	47,65	52,4	47,65
Ø E	25,4	19,1	25,4	19,1
F	140		146	
G	70		73	
Ø H	14,0		14,3	

Shaft torque limits [ml/rev. x bar]	
Shaft	Vi x p max.
1	16500
2	20600
3	20600
4	20600

**OPERATING CHARACTERISTICS - TYPICAL [24 cSt]**

Pressure port	Series	Vi Volumetric displacement	Flow q <sub>v</sub> [l/min] & n = 1500 RPM			Input power P [kW] & n = 1500 RPM		
			p = 0 bar	p = 140 bar	p = 320 bar	p = 7 bar	p = 140 abr	p = 320 bar
T7B T7BS	B02	5,8 ml/rev	8,7	7,0	4,8	0,5	2,6	5,4
	B03	9,8 ml/rev	14,7	13,0	10,8	0,6	4,0	8,6
	B04	12,8 ml/rev	19,2	17,5	15,3	0,6	5,0	11,0
	B05	15,9 ml/rev	23,9	22,2	20,0	0,7	6,1	13,5
	B06	19,8 ml/rev	29,7	28,0	25,8	0,7	7,5	16,6
	B07	22,5 ml/rev	33,7	32,0	29,9	0,8	8,5	18,8
	B08	24,9 ml/rev	37,4	35,7	33,5	0,8	9,3	20,7
	B09	28,0 ml/rev	42,0	40,3	38,1	0,9	10,4	23,2
	B10	31,8 ml/rev	47,7	46,0	43,8	0,9	11,7	26,2
	B11	35,0 ml/rev	52,5	50,8	48,9 <sup>1)</sup>	1,0	12,8	27,0 <sup>1)</sup>
	B12	41,0 ml/rev	61,5	59,8	57,9 <sup>1)</sup>	1,1	14,9	31,5 <sup>1)</sup>
	B14	45,0 ml/rev	67,5	65,8	63,9 <sup>1)</sup>	1,2	16,3	34,5 <sup>1)</sup>
B15	50,0 ml/rev	75,0	73,3	71,6 <sup>2)</sup>	1,3	18,1	35,7 <sup>2)</sup>	

1) B11 - B12 - B14 = 300 bar max. int.

2) B15 = 280 bar max. int.