

**General Description**

Series N needle valves are ideal as speed controls on hydraulic and pneumatic systems where a reverse flow check is not needed. They provide excellent control and a reliable shut-off in a very small envelope.

**Operation**

A two-step needle allows fine adjustment at low flow by using the first three turns of the adjusting knob. The next three turns open the valve to full flow, and also provide standard throttling adjustments.

**Features**

- The exclusive “Colorflow” color-band reference scale on the valve stem is a great convenience and time-saver in setting the valve originally and in returning it to any previous setting.
- A simple set screw locks the valve on any desired setting.
- A tamperproof option (T) feature is also available to prevent accidental or intentional adjustment of flow setting.

**Specifications**

<b>Maximum Operating Pressure</b>	Brass: 140 Bar (2000 PSI); except for N1600 brass which is 35 Bar (500 PSI)  Steel & Stainless: 345 Bar (5000 PSI) for 200 thru 1220; Steel: 207 Bar (3000 PSI) for all other sizes
<b>Material</b>	Body: see ordering code Knob: Steel - Zinc plated Needle: 416 Stainless Steel Stainless Steel: 303 Stainless Steel Bodies: 303 Stainless Steel
<b>Operating Temperature</b>	-40°C to +121°C (-40°F to +250°F) Nitrile (standard) -26°C to +205°C (-15°F to +400°F) Fluorocarbon

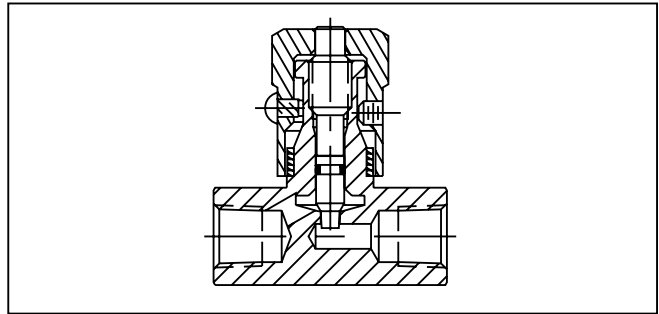
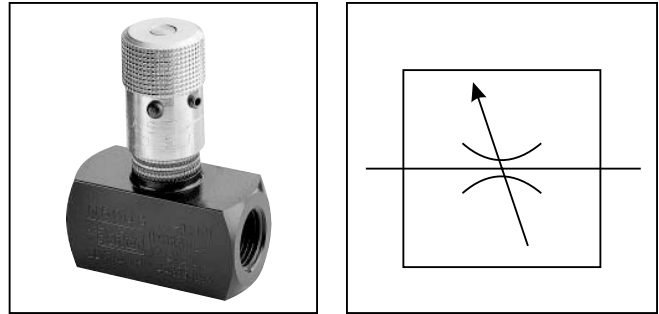

**Performance Curves**

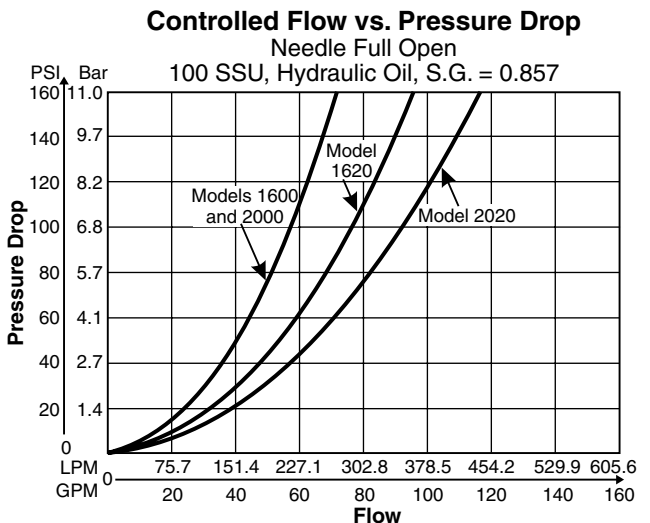
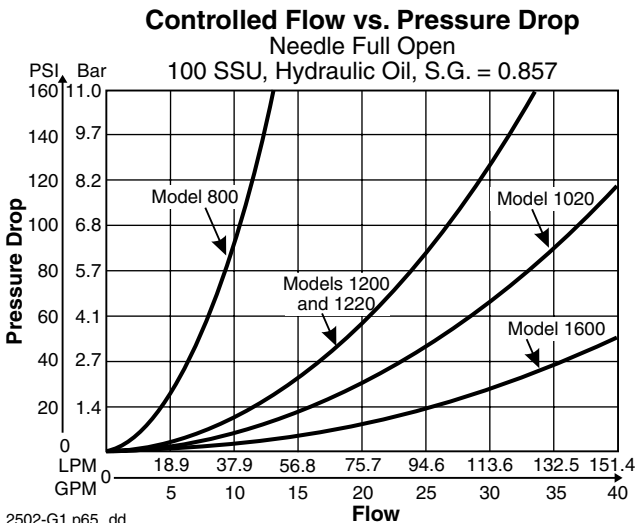
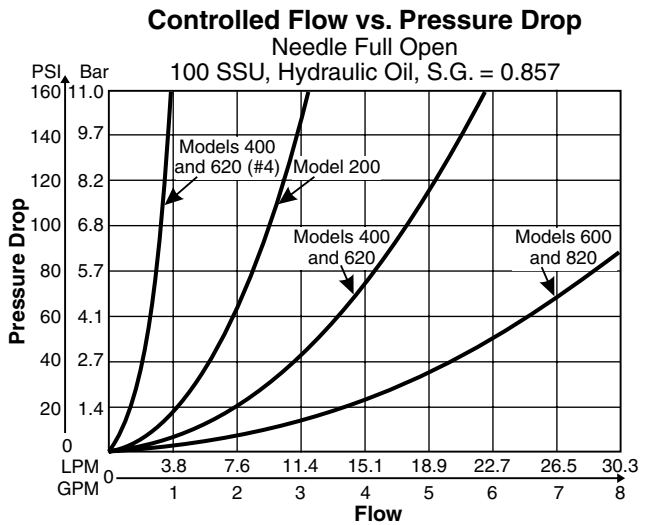

2502-G1.p65, dd



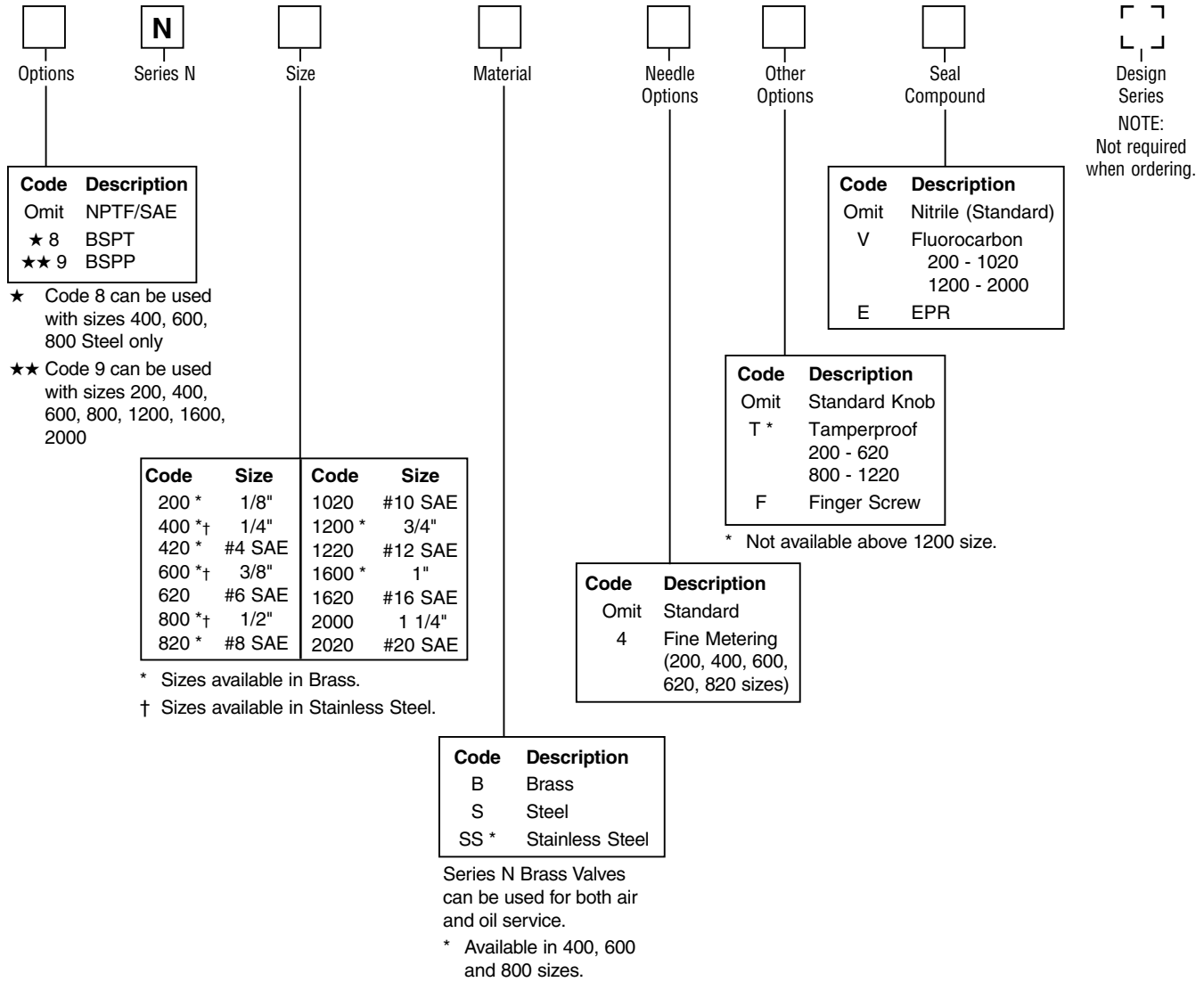

Model Number	Max Flow LPM (GPM)	Effective Orifice Area Control Flow in. <sup>2</sup>	Effective Control Flow C <sub>v</sub>
N200	11 (3)	0.0102	0.230
N420	11 (3)	0.0102	0.230
N400	19 (5)	0.0194	0.443
N620	19 (5)	0.0194	0.443
N600	30 (8)	0.0344	0.787
N820	30 (8)	0.0344	0.787
N800	57 (15)	0.0427	0.976
N1020	57 (15)	0.0427	0.976
N1200	95 (25)	0.1080	2.470
N1220	95 (25)	0.1080	2.470
N1600	151 (40)	0.2300	5.250
N1620	151 (40)	0.3070	7.000
N2000	264 (70)	0.2300	5.250
N2020	264 (70)	0.3710	8.470
N2400	379 (100)	0.2300	5.250



Inch equivalents for millimeter dimensions are shown in (\*\*)

**Knob Options**

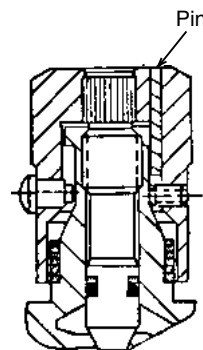
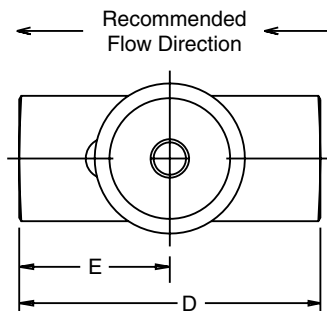

Tamperproof Option (Code "T") permanently locks knob at desired flow setting by installing a pin in predrilled hole.

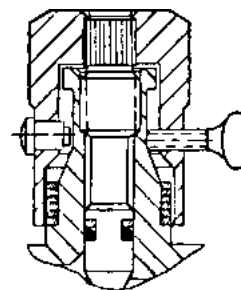

Finger screw Option (Code "F") provides this thumb-screw in place of set screw.

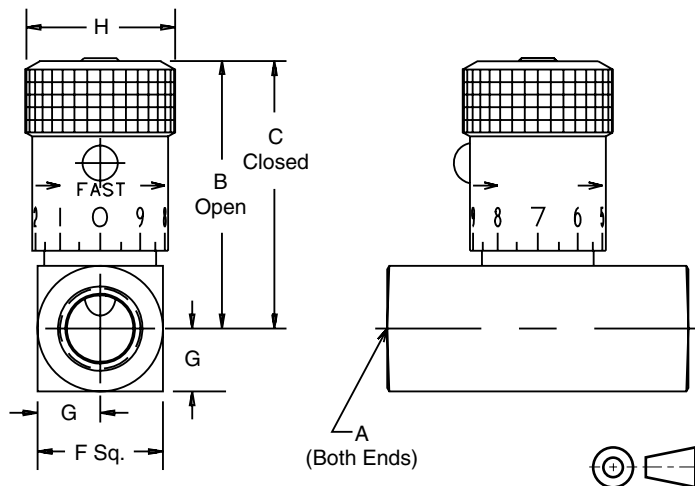

Model Number	Weight kg (lbs.)	A	B	C	D	E	F	G	H
N200	0.1 (0.3)	1/8-27 NPTF	39.1 (1.54)	35.3 (1.39)	38.1 (1.50)	19.1 (0.75)	15.7 (0.62)	7.9 (0.31)	19.1 (0.75)
N400	0.2 (0.5)	1/4-18 NPTF	45.5 (1.79)	40.4 (1.59)	50.8 (2.00)	25.4 (1.00)	20.6 (0.81)	10.4 (0.41)	20.6 (0.81)
N420	0.1 (0.3)	7/16-20 UNF #4 SAE	41.4 (1.63)	37.6 (1.48)	50.8 (2.00)	25.4 (1.00)	20.6 (0.81)	10.4 (0.41)	19.1 (0.75)
N600	0.4 (0.9)	3/8-18 NPTF	55.4 (2.18)	49.5 (1.95)	63.5 (2.50)	31.8 (1.25)	25.4 (1.00)	12.7 (0.50)	25.4 (1.00)
N620	0.2 (0.5)	9/16-18 UNF #6 SAE	47.8 (1.88)	42.7 (1.68)	60.5 (2.38)	30.2 (1.19)	25.4 (1.00)	12.7 (0.50)	20.6 (0.81)
N800	0.6 (1.4)	1/2-14 NPTF	68.6 (2.70)	61.5 (2.42)	66.5 (2.62)	33.3 (1.31)	31.8 (1.25)	15.7 (0.62)	30.2 (1.19)
N820	0.4 (0.9)	3/4-16 UNF #8 SAE	56.9 (2.24)	51.1 (2.01)	76.2 (3.00)	38.1 (1.50)	28.4 (1.12)	14.2 (0.56)	25.4 (1.00)
N1020	0.6 (1.3)	7/8-14 UNF #10 SAE	68.6 (2.70)	61.5 (2.42)	88.9 (3.50)	44.5 (1.75)	31.8 (1.25)	15.7 (0.62)	30.2 (1.19)
N1200	1.0 (2.3)	3/4-14 NPTF	85.9 (3.38)	71.4 (2.81)	82.6 (3.25)	41.1 (1.62)	38.1 (1.50)	19.1 (0.75)	35.1 (1.38)
N1220	1.0 (2.3)	1 1/6-12 UN #12 SAE	85.9 (3.38)	71.4 (2.81)	101.6 (4.00)	50.8 (2.00)	38.1 (1.50)	19.1 (0.75)	35.1 (1.38)
N1600	2.1 (4.7)	1-11 1/2 NPTF	123.7 (4.87)	106.9 (4.21)	108.0 (4.25)	53.8 (2.12)	44.5 (1.75)	22.4 (0.88)	47.8 *
N1620	2.1 (4.7)	1 5/16-12 UN #16 SAE	130.8 (5.15)	114.0 (4.49)	108.0 (4.25)	53.8 (2.12)	57.2 (2.25)	28.4 (1.12)	47.8 *
N2000	2.9 (6.4)	1 1/4-11 1/2 NPTF	130.0 (5.12)	113.3 (4.46)	108.0 (4.25)	53.8 (2.12)	57.2 (2.25)	28.4 (1.12)	47.8 *
N2020	2.9 (6.4)	1 5/8-12 UN #20 SAE	140.2 (5.52)	123.4 (4.86)	114.3 (4.50)	57.2 (2.25)	69.9 (2.75)	60.5 (2.38)	47.8 *

\* = Hex

