

**Valvola OVERCENTER semplice effetto in linea**  
**In line single OVERCENTER valve**  
**mod. OVC - SE - L**

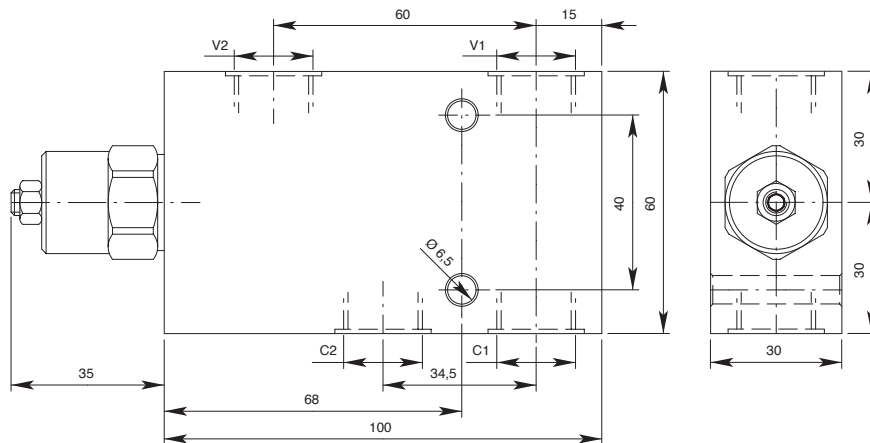
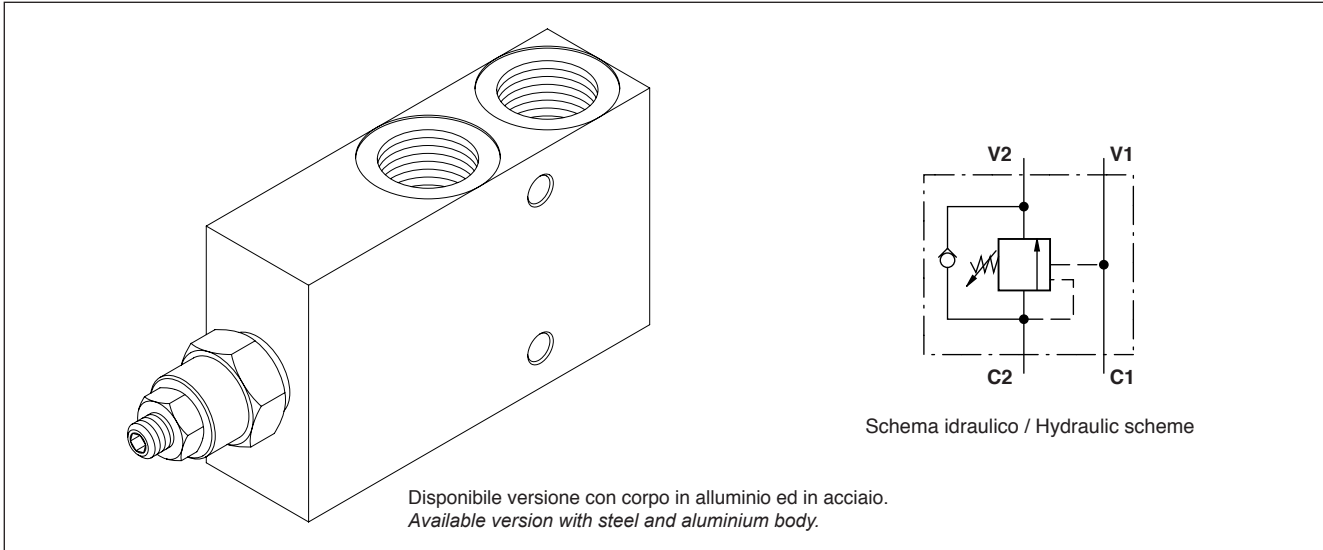

Modello Type	V1 V2 C1 C2	Portata max Max flow l/ min	Rapporto pilotaggio Pilot ratio	Pressione massima Max pressure bar
OVC-SE-L-38	3/8" gas	40	4,25/1	350
OVC-SE-L-12	1/2" gas	60		

A richiesta rapporti di pilotaggio 3/1, 8/1 e 10/1. Pilot ratios 3/1, 8/1 and 10/1 on request.

Tutti i dati forniti sono stati ottenuti usando olio con viscosità di circa 30cSt a 50°C. Campo di temperatura ammesso: -20°C, +90°C. Filtrazione assoluta: 25µ. I dati non sono impegnativi, CBF si riserva di apportare modifiche senza preavviso.  
All performances and calibrations are carried out by using hydraulic oil with viscosity approx. 30cSt at 50°C. Temperature range: -20°C, +90°C. Filtration absolute: 25µ. The specifications are not binding, CBF reserves the right to introduce modifications without notice.

Sigla di ordinazione / Ordering code

**OVC-SE-L-38 - 01**

Modello / Type	Codice Molle: 01, 02 Spring code: 01, 02
----------------	---

Per ordinare la versione con corpo in acciaio, aggiungere al codice A.  
For steel body version, please, add A to ordering code.

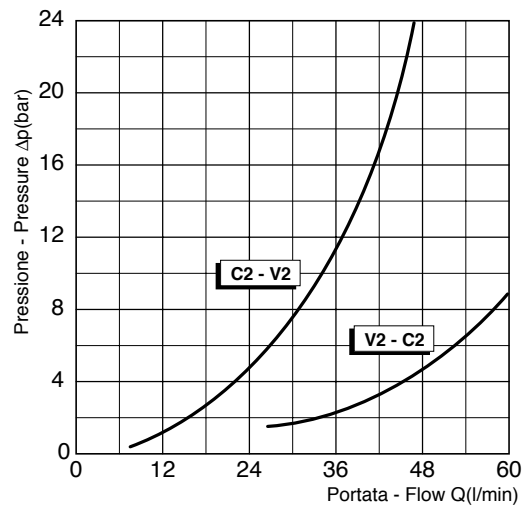

Molle - Springs			
Codice Code	Taratura standard Standard setting bar (Q=5 l/min)	Campo di taratura Adj. pressure range bar	Colore Colour
01	100	20 ÷ 200	Bianco / White
02	280	50 ÷ 350	Nero / Black